

Table of Contents

| | |
|--|----|
| 1. Introduction | 7 |
| Step 1 - All the required tools are included | 8 |
| Step 2 - Additional utilities for this guide | 8 |
| Step 3 - Labels guide | 9 |
| Step 4 - Spare bag | 9 |
| Step 5 - View high resolution images | 10 |
| Step 6 - Printed parts - versioning | 10 |
| Step 7 - We are here for you! | 11 |
| Step 8 - Pro tip: inserting the nuts | 12 |
| Step 9 - Important: Electronics protection | 13 |
| Step 10 - Reward yourself | 14 |
| Step 11 - How to successfully finish the assembly | 15 |
| Step 12 - Prepare your desk | 16 |
| 2. Frame assembly | 17 |
| Step 1 - Tools necessary for this chapter | 18 |
| Step 2 - YZ frame: parts preparation | 18 |
| Step 3 - YZ frame: mounting the longer extrusions | 19 |
| Step 4 - YZ frame: mounting the shorter extrusions | 19 |
| Step 5 - YZ frame: final check | 20 |
| Step 6 - Y-axis: front and rear plate preparation | 20 |
| Step 7 - Y-axis: front plate assembly | 21 |
| Step 8 - Y-axis: preparation for the PSU and xBuddy-box | 21 |
| Step 9 - Y-axis: rear plate assembly | 22 |
| Step 10 - Y-axis: geometry check | 23 |
| Step 11 - Mounting antivibration feet and cable clips: parts preparation | 23 |
| Step 12 - Mounting antivibration feet | 24 |
| Step 13 - Installing the cable clips | 24 |
| Step 14 - Installing the cable clips | 25 |
| Step 15 - PSU: parts preparation | 25 |
| Step 16 - Attaching the PSU | 26 |
| Step 17 - Attaching the PSU | 26 |
| Step 18 - xBuddyBox: parts preparation | 27 |
| Step 19 - Mounting the xBuddyBox: parts preparation | 27 |
| Step 20 - Mounting the xBuddyBox | 28 |
| Step 21 - Mounting the xBuddyBox | 28 |
| Step 22 - Mounting the xBuddyBox | 29 |
| Step 23 - Applying the thermal pads | 29 |
| Step 24 - Mounting the xBuddy board | 30 |
| Step 25 - Attaching the zip ties | 30 |
| Step 26 - Preparing Y-belt-idler (part 1) | 31 |
| Step 27 - Preparing Y-belt-idler (part 2) | 31 |
| Step 28 - Mounting the Y-belt-idler | 32 |
| Step 29 - Assembling the Y motor: parts preparation | 32 |
| Step 30 - Assembling the Y motor | 33 |
| Step 31 - Assembling the Y-motor-holder | 33 |
| Step 32 - Assembling the Y-motor-holder | 34 |
| Step 33 - Attaching the Y-motor-holder | 34 |
| Step 34 - Haribo | 35 |
| Step 35 - It's done! | 35 |
| 3. X-axis & X-carriage assembly | 36 |

| | |
|--|-----------|
| Step 1 - Tools necessary for this chapter | 37 |
| Step 2 - X-axis assembly: parts preparation | 37 |
| Step 3 - Assembling the X-end-motor | 38 |
| Step 4 - Assembling the X-end-motor | 38 |
| Step 5 - Assembling the X-end-idler | 39 |
| Step 6 - Assembling the X-end-idler | 39 |
| Step 7 - Assembling the X-end-idler | 40 |
| Step 8 - Mounting the bearings: parts preparation | 40 |
| Step 9 - Mounting the bearings: parts preparation (lubricating) | 41 |
| Step 10 - Lubricating the bearing | 41 |
| Step 11 - Lubricating the bearing | 42 |
| Step 12 - Inserting the bearings: X-end-motor | 42 |
| Step 13 - Inserting the bearings: bearing pads | 43 |
| Step 14 - Covering the bearings: X-end-motor | 43 |
| Step 15 - Inserting the bearings: X-end-idler | 44 |
| Step 16 - Assembling the X-axis: parts preparation | 44 |
| Step 17 - Assembling the X-axis: Marking the bearings | 45 |
| Step 18 - Assembling the X-axis: parts preparation (lubricating) | 45 |
| Step 19 - Lubricating the bearing | 46 |
| Step 20 - Lubricating the bearing | 46 |
| Step 21 - Assembling the X-axis: Inserting smooth rods | 47 |
| Step 22 - Assembling the X-axis: mounting the X-end-motor | 47 |
| Step 23 - Assembling the X-carriage: parts preparation | 48 |
| Step 24 - Assembling the X-carriage | 48 |
| Step 25 - Attaching the spacers | 49 |
| Step 26 - Attaching the spacers | 49 |
| Step 27 - Assembling the X-carriage-clip: parts preparation | 50 |
| Step 28 - Assembling the X-carriage-clip | 50 |
| Step 29 - Attaching the X-carriage-clip | 51 |
| Step 30 - Attaching the X motor: parts preparation | 52 |
| Step 31 - Attaching the X motor | 52 |
| Step 32 - Attaching the X motor: mounting the pulley | 53 |
| Step 33 - Guiding the X belt: parts preparation | 53 |
| Step 34 - Guiding the X belt: X-end-idler | 54 |
| Step 35 - Guiding the X belt: X-end-motor | 54 |
| Step 36 - Guiding the X belt: X-carriage | 55 |
| Step 37 - Assembling the X-carriage: final check | 55 |
| Step 38 - Haribo | 56 |
| Step 39 - It's done! | 56 |
| 4. Z-axis assembly | 57 |
| Step 1 - Tools necessary for this chapter | 58 |
| Step 2 - Assembling the Z-bottoms: parts preparation | 58 |
| Step 3 - Assembling the Z-bottoms | 59 |
| Step 4 - Z motor assembling: parts preparation | 59 |
| Step 5 - Attaching the rubber pads | 60 |
| Step 6 - Installing the Z motors | 60 |
| Step 7 - Connecting the Z motors | 61 |
| Step 8 - Mounting the X-axis assembly: parts preparation | 61 |
| Step 9 - Mounting the X-axis and smooth rods | 62 |
| Step 10 - Assembling the X-axis and smooth rods | 62 |
| Step 11 - Installing the X-axis assembly | 63 |
| Step 12 - Assembling the trapezoidal nuts | 63 |
| Step 13 - Installing the Z-top parts: parts preparation | 64 |
| Step 14 - Placing the Z-top parts | 64 |

| | |
|---|-----------|
| Step 15 - LoveBoard: parts preparation | 65 |
| Step 16 - Assembling the LoveBoard | 65 |
| Step 17 - Connecting the extruder main cable | 66 |
| Step 18 - Mounting the extruder main cable | 66 |
| Step 19 - Connecting the extruder main cable: parts preparation | 67 |
| Step 20 - Connecting the extruder main cable | 67 |
| Step 21 - Covering the X-carriage: parts preparation | 68 |
| Step 22 - Covering the X-carriage: inserting the nylon filament | 68 |
| Step 23 - Attaching the X-cover-back | 69 |
| Step 24 - Guiding the main-cable: parts preparation | 69 |
| Step 25 - Wrapping the extruder main cable | 70 |
| Step 26 - Wrapping the textile sleeve | 70 |
| Step 27 - Attaching the Ext-cable-holder: parts preparation | 71 |
| Step 28 - Wrapping the X motor cable | 71 |
| Step 29 - Attaching the Ext-cable-holder | 72 |
| Step 30 - Assembling the Ext-cable-holder | 72 |
| Step 31 - Assembling the Ext-cable-holder | 73 |
| Step 32 - Assembling the Ext-cable-holder | 73 |
| Step 33 - Reward yourself! | 74 |
| Step 34 - Here it is! | 74 |
| 5. Nextruder assembly | 75 |
| Step 1 - Tools necessary for this chapter | 76 |
| Step 2 - Filament sensor: parts preparation | 76 |
| Step 3 - Assembling the filament sensor | 77 |
| Step 4 - Assembling the filament sensor | 77 |
| Step 5 - Nextruder idler assembly: parts preparation | 78 |
| Step 6 - Assembling the extruder idler | 78 |
| Step 7 - Assembling the extruder: parts preparation I. | 79 |
| Step 8 - Assembling the extruder: parts preparation II. | 79 |
| Step 9 - Assembling the extruder | 80 |
| Step 10 - Assembling the gearbox | 80 |
| Step 11 - Assembling the PG-ring | 81 |
| Step 12 - Assembling the PG-assembly | 81 |
| Step 13 - Checking the PG-assembly | 82 |
| Step 14 - Assembling the Nextruder idler | 82 |
| Step 15 - Covering the planetary gear | 83 |
| Step 16 - Assembling the Idler-swivel: parts preparation | 83 |
| Step 17 - Assembling the Idler-swivel | 84 |
| Step 18 - Assembling the Idler-nut | 84 |
| Step 19 - Mounting the Idler-swivel assembly | 85 |
| Step 20 - Attaching the extruder: parts preparation | 85 |
| Step 21 - Assembling the heatsink | 86 |
| Step 22 - Attaching the extruder | 86 |
| Step 23 - Connecting the NTC thermistor | 87 |
| Step 24 - Assembling the hotend fan: parts preparation | 87 |
| Step 25 - Assembling the hotend fan | 88 |
| Step 26 - Inserting the hotend assembly: parts preparation | 88 |
| Step 27 - Inserting the hotend assembly | 89 |
| Step 28 - Connecting the hotend cables | 89 |
| Step 29 - Assembling the fan-door: parts preparation | 90 |
| Step 30 - Assembling the fan door | 90 |
| Step 31 - Assembling the fan-door | 91 |
| Step 32 - Assembling the fan-door | 91 |
| Step 33 - Assembling the fan-door | 92 |

| | |
|---|------------|
| Step 34 - Assembling the fan-door | 92 |
| Step 35 - Connecting the extruder cables | 93 |
| Step 36 - Connecting the print fan | 93 |
| Step 37 - LoveBoard: Wiring check | 94 |
| Step 38 - Covering the LoveBoard: parts preparation | 94 |
| Step 39 - Covering the LoveBoard | 95 |
| Step 40 - Covering the LoveBoard | 95 |
| Step 41 - Tensioning the X-axis belt | 96 |
| Step 42 - Belt tension check | 96 |
| Step 43 - Testing the X-axis belt | 97 |
| Step 44 - Haribo time! | 97 |
| Step 45 - The extruder is assembled | 98 |
| 6. xLCD assembly | 99 |
| Step 1 - Tools necessary for this chapter | 100 |
| Step 2 - xLCD assembly: parts preparation (part 1) | 100 |
| Step 3 - xLCD assembly: parts preparation (part 2) | 101 |
| Step 4 - xLCD assembly: inserting the square nuts | 101 |
| Step 5 - Installing the xReflector sticker | 102 |
| Step 6 - Assembling the xLCD | 102 |
| Step 7 - Assembling the xLCD-support-right | 103 |
| Step 8 - Assembling the xLCD-support-left | 103 |
| Step 9 - Attaching the xLCD assembly: parts preparation | 104 |
| Step 10 - Connecting the PE cable | 104 |
| Step 11 - Attaching the knob | 105 |
| Step 12 - Attaching the xLCD assembly | 105 |
| Step 13 - Guiding the xLCD cable | 106 |
| Step 14 - Connecting the PSU: parts preparation | 106 |
| Step 15 - Connecting the PSU: PE cable | 107 |
| Step 16 - Power cables info | 108 |
| Step 17 - Connecting the PSU | 109 |
| Step 18 - Connecting the power panic | 110 |
| Step 19 - Guiding the Z motor right cable | 110 |
| Step 20 - Guiding the power cable bundle | 111 |
| Step 21 - Guiding the power cables | 111 |
| Step 22 - Connecting the X and Y motor cables | 112 |
| Step 23 - Connecting the PSU cable: parts preparation | 112 |
| Step 24 - Connecting the PSU cables: PE cable | 113 |
| Step 25 - Connecting the PSU cables: | 113 |
| Step 26 - Securing the PSU cables | 114 |
| Step 27 - Guiding the Z motor left cable | 114 |
| Step 28 - Connecting the xLCD cables | 115 |
| Step 29 - Connecting the extruder main cable | 115 |
| Step 30 - Time for energy delivery! | 116 |
| Step 31 - Almost there! | 116 |
| 7. Y-carriage & Heatbed assembly | 117 |
| Step 1 - Tools necessary for this chapter | 118 |
| Step 2 - Heatbed cable assembly: parts preparation | 118 |
| Step 3 - Heatbed cable assembly (part 1) | 119 |
| Step 4 - Heatbed cable assembly (part 2) | 119 |
| Step 5 - Heatbed cable assembly (part 3) | 120 |
| Step 6 - Covering the heatbed cables: parts preparation | 120 |
| Step 7 - Assembling the heatbed-cable-cover-bottom | 121 |
| Step 8 - Assembling the heatbed-cable-cover: nylon filament | 121 |
| Step 9 - Assembling the heatbed-cable-cover-bottom | 122 |

| | |
|--|------------|
| Step 10 - Assembling the heatbed-cable-cover-top | 122 |
| Step 11 - Wrapping the textile sleeve | 123 |
| Step 12 - Assembling the Y-carriage: parts preparation | 123 |
| Step 13 - Y-carriage: parts preparation (lubricating) | 124 |
| Step 14 - Lubricating the bearing | 124 |
| Step 15 - Lubricating the bearing | 125 |
| Step 16 - Assembling the bearing clips | 125 |
| Step 17 - Installing the bearing on the Y-carriage | 126 |
| Step 18 - Aligning the bearing | 126 |
| Step 19 - Installing the bearings on the Y-carriage | 127 |
| Step 20 - Y-axis: smooth rods holders | 127 |
| Step 21 - Preparing Y-rod-holder | 128 |
| Step 22 - Inserting smooth rods into Y-carriage | 128 |
| Step 23 - Mounting the Y-rod-holder parts | 129 |
| Step 24 - Installing the Y-carriage | 129 |
| Step 25 - Aligning the smooth rods | 130 |
| Step 26 - Assembling the Y belt: parts preparation | 130 |
| Step 27 - Assembling the Y belt | 131 |
| Step 28 - Assembling the Y belt | 131 |
| Step 29 - Assembling the Y belt holder | 132 |
| Step 30 - Assembling the Y belt tensioner | 132 |
| Step 31 - Assembling the Y belt tensioner | 133 |
| Step 32 - Tensioning the Y belt | 133 |
| Step 33 - Belt tension check | 134 |
| Step 34 - Aligning the Y belt | 134 |
| Step 35 - Installing the Expansion joints: parts preparation | 135 |
| Step 36 - Preparing the expansion joints | 135 |
| Step 37 - Installing the Expansion joints | 136 |
| Step 38 - Attaching the heatbed: parts preparation | 136 |
| Step 39 - Attaching the heatbed | 137 |
| Step 40 - Tightening the heatbed | 137 |
| Step 41 - Guiding the heatbed cables: parts preparation | 138 |
| Step 42 - Guiding the heatbed cables | 138 |
| Step 43 - Covering the heatbed cables | 139 |
| Step 44 - Verify all connections once more! | 139 |
| Step 45 - Installing the ESP module: parts preparation | 140 |
| Step 46 - Installing the ESP module | 140 |
| Step 47 - Covering the xBuddyBox: parts preparation | 141 |
| Step 48 - Covering the xBuddy Box | 141 |
| Step 49 - Covering the xBuddyBox | 142 |
| Step 50 - Assembling the double spool holder (part 1) | 142 |
| Step 51 - Assembling the double spool holder (part 2) | 143 |
| Step 52 - Assembling the Filament guide: parts preparation | 143 |
| Step 53 - Filament guide assembly (part 1) | 144 |
| Step 54 - Filament guide assembly (part 2) | 144 |
| Step 55 - Haribo time! | 145 |
| Step 56 - That's it | 145 |
| 8. Preflight check | 146 |
| Step 1 - Attaching the steel sheet | 147 |
| Step 2 - Firmware update (part 1) | 148 |
| Step 3 - Firmware update (part 2) | 148 |
| Step 4 - Wizard - Selftest start | 149 |
| Step 5 - Wizard - Loadcell Test | 149 |
| Step 6 - Wizard - Gearbox Alignment | 150 |

| | |
|---|------------|
| Step 7 - Wizard - Filament Sensor Calibration | 150 |
| Step 8 - Wizard complete | 151 |
| Step 9 - Reward yourself! | 151 |
| Step 10 - Loading a filament | 152 |
| Step 11 - Printable 3D models | 152 |
| Step 12 - PrusaSlicer for MK4 | 153 |
| Step 13 - PrusaLink and Prusa Connect | 153 |
| Step 14 - Quick guide for your first prints | 154 |
| Step 15 - Prusa knowledge base | 154 |
| Step 16 - Join Printables! | 154 |
| Manual changelog MK4 kit | 155 |
| Step 1 - Version history | 156 |

1. Introduction

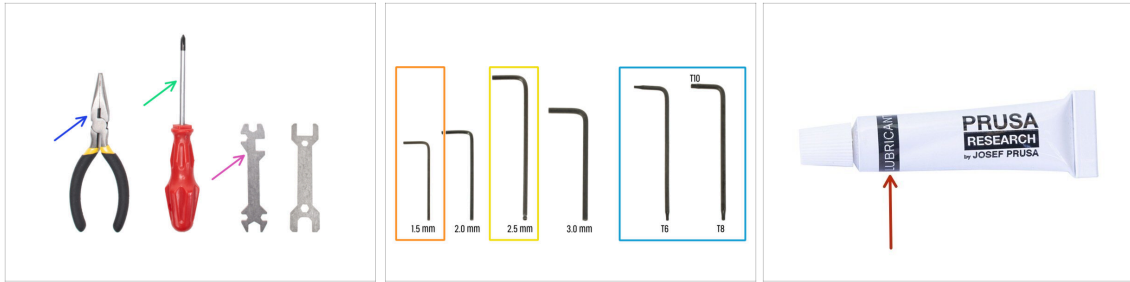

STEP 1 All the required tools are included

● The tool package can be found in the Fasteners & ELE box. The tool package includes:

- Needle-nose pliers (1x)
- Philips (PH2) screwdriver (1x)
- Universal wrench (1x)
- Wrench size 13 mm (1x)
- Torx key set
- Allen key set
- Lubricant

STEP 2 Additional utilities for this guide

● Some steps in the manual will require commonly available items to help you with assembly (not included in the kit):

- Scissors - *For cutting a bag with bearings*
- Permanent marker - choose black or another dark color. *The marker will come in handy a few chapters further, for marking bearings and magnets.*
- Paper towels or piece of cloth - *For wiping residual grease off the bearings and smooth rods and as a soft pad for preparing the Y-carriage assembly.*

ⓘ No soldering or wire crimping is required.

STEP 3 Labels guide

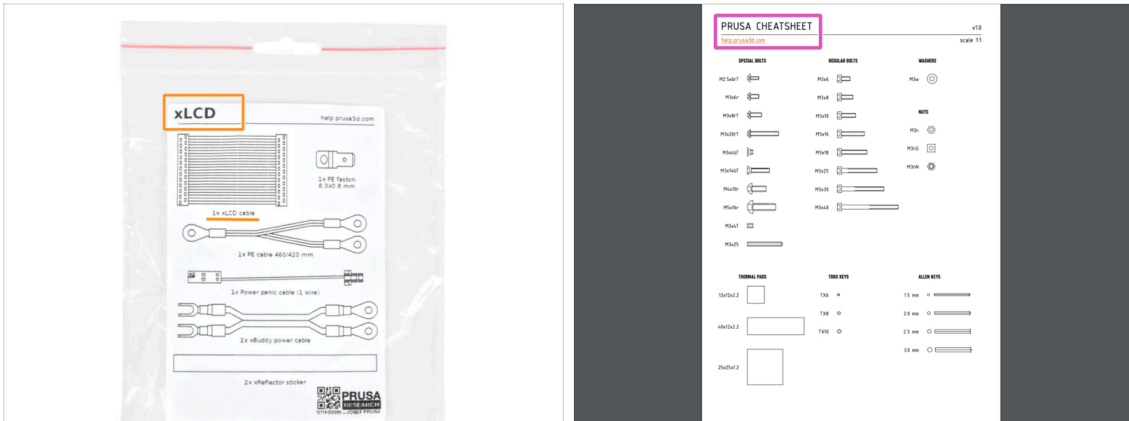

- All the boxes and bags including parts for the build are labeled.
- The labels include the list of contents and part count.
- You can download a **Cheatsheet** with 1:1 fastener drawings from our site prusa.io/cheatsheet-mk4. Print it at 100 %, don't rescale it, otherwise, it won't work.
- ⓘ For PRUSA veterans: Fasteners are divided into individual bags according to its type. Not into packages for individual chapters, as it was with previous printers.

STEP 4 Spare bag



- There is a bag with spare parts like thermal pads, springs, etc.
- Spare fasteners are included in each bag of fasteners. The numbers in parentheses below the fastener picture indicate the number of extra pieces added to the SPARE package.

STEP 5 View high resolution images



- ◆ When you browse the guide on help.prusa3d.com, you can view the original images in high resolution for clarity.
- ◆ Just hover your cursor over the image and click the Magnifier button ("View original") in the top left corner.

STEP 6 Printed parts - versioning

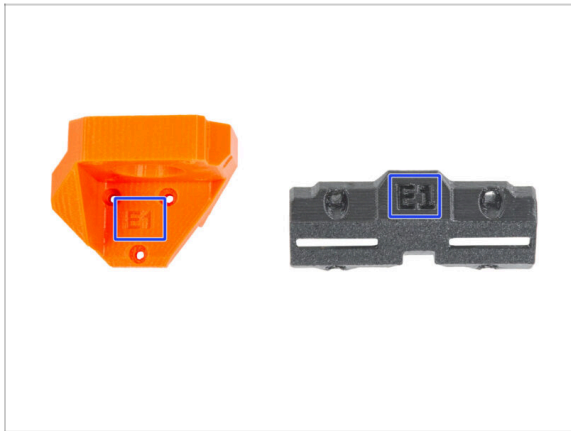

- ◆ Most of the 3D printed parts on Original Prusa MK4 are marked with their version.
 - ◆ **E, F and Gx series** (e.g. E1) - those parts are printed on Prusa Research farm and are distributed with the kit.
 - ◆ **R, S and Tx series** (e.g. R1) - those parts are available for download at prusa.io/printable-parts-mk4. They are identical to the factory ones.
- ⓘ In case you have issues while assembling the printer with the certain printed part, please try to find this label and tell it to our support team.

STEP 7 We are here for you!

The screenshot displays a two-column layout. The left column contains a table of contents with steps 3 through 15. The right column features 'Step 13 Assembling the Nextrunder idler' with an image of a hand holding a component and a list of instructions. Below the instructions is a comment box with a 'SUBMIT' button. To the right of this is another section with a warning icon, a tip icon, and a 'SUBMIT' button. A pink arrow points from the 'SUBMIT' button in the second section to a 'Chat now' button at the bottom right.

Step 13 Assembling the Nextrunder idler

- Insert the idler assembly between the PG-ring and the extruder motor. There is a cutout for the spacer in the main-plate. Line up the idler spacer with the hole in the PG-ring.
- Secure both parts with grub screw 3x25. Do not overtighten the screw! The grub screw protrudes from the PG-ring after tightening.
- Apply a small amount of Prusa Lubricant all around the PG-ring and PG-assembly teeth.
- Tip: apply a small amount of lubricant to the tip of the zip tie and then spread the lubricant over the gears.
- Using a paper towel, wipe off any excess lubricant on the front surfaces.

Secure both parts with grub screw 3x25. Do not overtighten the screw! The grub screw protrudes from the PG-ring after tightening.

Apply a small amount of Prusa Lubricant all around the PG-ring and PG-assembly teeth.

Tip: apply a small amount of lubricant to the tip of the zip tie and then spread the lubricant over the gears.

Using a paper towel, wipe off any excess lubricant on the front surfaces.

2 comments

POWERED BY TINY

SUBMIT

Chat now

- 🛡️ Lost in the instructions, missing screw or cracked printed part? **Let us know!**
- 🛡️ You can contact us using the following channels:
 - 🟢 Using comments under each step.
 - 🟣 Using our 24/7 live chat here at help.prusa3d.com
 - 🛡️ Writing an email to info@prusa3d.com

STEP 8 Pro tip: inserting the nuts

- 3D printed parts are very precise, however, there still might be a tolerance in the printed part and same goes for the size of the nut.
- Therefore it might happen, that the nut won't fit easily in or might be falling out. Let's see, how to fix it:
 - **Nut won't fit in:** use a screw with a thread along its entire length (typically: M3x10, M3x18) and screw it from the opposite side of the opening. While tightening the screw, the nut will be pulled in. Remove the screw afterwards.
 - **Alternative option:** you can use X-holder tool included in the package. Insert any screw (typically: M3x10 or M3x18) and screw the nut fully on the tip of the thread. Push the nut into the printed part and remove the screw with X-holder.
 - **Nut keeps falling out:** Use a piece of tape to fix the nut temporarily in place, as soon as you insert the screw in, you can remove the tape. *Using glue isn't recommended as it can partly reach into the thread and you won't be able to tighten the screw properly.*
- Every time we recommend to use the "screw pulling technique", you will be reminded with Joe's avatar ;)
- ⓘ Parts in the pictures are used as an example.

STEP 9 Important: Electronics protection

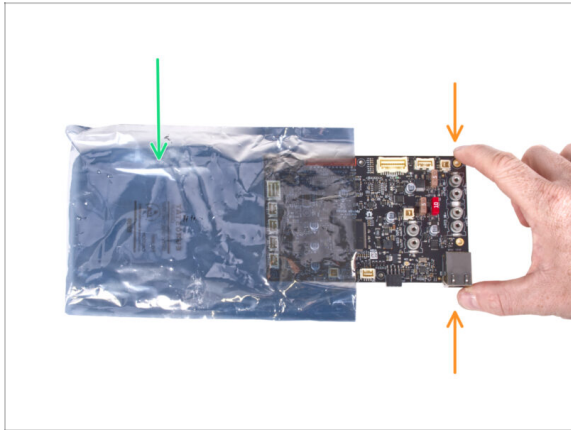

⚠ WARNING: Make sure to **protect the electronics against electrostatic discharge (ESD)**. Always unpack the electronics right before you need them!

Here are some **tips to prevent damage to the electronics:**

- **Keep the electronics inside the ESD bag** right until you are asked to install them.
- **Always touch the sides of the board only** while handling it. Avoid touching the components on the surface.
- **Before you touch the electronics** use any conductive (metal) structure nearby to neutralize the possible static charge from your hands.
- Be extra cautious **in rooms with carpets**, which are often a source of electrostatic energy.
- Clothes made of wool or certain synthetic fabrics can easily gather static electricity too. It is safer to wear cotton clothing for the assembly.

STEP 10 Reward yourself



- ◆ Based on the feedback, building the MK4 printer is even more enjoyable compared to the MK3S+. However, you should still treat yourself for every finished chapter. Look in the box and find bag of Haribo Bears.
- ⚠ **The biggest issue from our experience (MK3S+, MK3S, MK3, MK2S, ...) is inadequate bear consumption. Many of you didn't have enough gummy bears for all chapters, some even ate them all before they started!**
- ◆ After years of thorough scientific research, we came to a solution => At the end of each chapter, you will be told a specific amount of bears to consume.
- ◆ Eating incorrect amount than prescribed in the manual might lead to sudden boost of energy. Please consult a professional in the closest candy store.
- ⚠ **Hide the Haribo for now! From our experience an unattended bag with sweets will suddenly disappear. Confirmed by multiple cases all around the World.**

STEP 11 How to successfully finish the assembly

Step 25 Attaching the spacers



- Insert two M3n nuts to the X-carriage-back.
- ① Use the screw pulling technique.
- From the opposite side, insert the M3x10 screw into the X-carriage-back. The screw must protrude from the "front" side of the part.
- Attach the spacer 10 mm on the M3x10 screw and tighten the screw. **Note the cutout of the same shape as the spacer. It must fit perfectly and must not rotate.**



2 comments

 **To successfully finish the MK4 kit please follow all these:**

- ◆ **Always read all the instructions at current step first**, it will help you to understand what you need to do. Don't cut or trim unless you are told to!!!
- ◆ **Don't follow pictures only!** It is not enough, the written instructions are as brief as they could be. **Read them!**
- ◆ Read the comments from the other users, they are great source of ideas. We read them too and based on your feedback improve the manual and the entire assembly.
- ◆ **Use a reasonable force**, the printed parts are tough, but not unbreakable. If it doesn't fit, check your approach twice.
- ◆ **Eat the gummy bears as instructed!** Disobedience won't be tolerated :D
- ◆ **Most important: Enjoy the build, have fun.** Cooperate with your kids, friends or partners.

STEP 12 Prepare your desk



- ◆ **Tidy up your desk!** Tidying up decreases the probability of losing small parts.
- ◆ **Clear your workspace.** Make sure you have enough room. A nice clear flat workbench will get you the results you are aiming for.
- ◆ **Let there be light!** Make sure you are in a well-lit environment. Another lamp or even an extra flashlight will probably come in handy.
- ◆ Prepare something to contain the plastic bags and the removed packing materials so you can recycle them afterwards. Make sure there are no important parts being discarded.
- ◆ OK, we are ready. Let's start! Go to chapter **2. Frame assembly**

2. Frame assembly



STEP 1 Tools necessary for this chapter

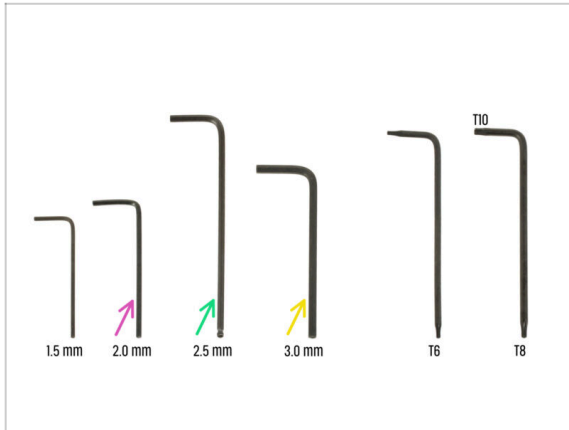

- **For this chapter, please prepare:**
- 2.0mm Allen key for tightening the grub screws
- 2.5mm Allen key for most of the M3 screws on the assembly
- 3mm Allen key for M5 screws used on the frame

STEP 2 YZ frame: parts preparation

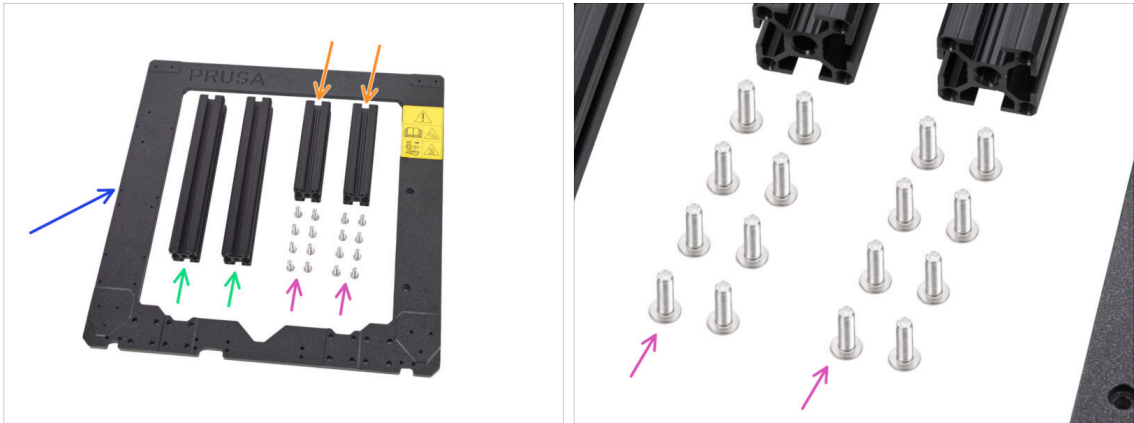

● **Prepare the following parts to build the YZ frame:**

- Extrusion 3030 120 mm (2x)
- Extrusion 3030 205 mm (2x)
- Printer frame (1x)
- M5x16r screw (16x)

⚠ **Before you proceed further, please place the frame on a flat surface.**

STEP 3 YZ frame: mounting the longer extrusions



- ◆ Take the **LONGER** extrusions and place them next to the frame.
- ⚠ **Make sure the engraved PRUSA logo (top left) on the frame is visible. This is the front side. The longer extrusions are going to be mounted to the front side.**
- ⓘ Note: screws are inserted from the opposite side of the frame. If you need to manipulate with the frame, make sure the extrusions are on the correct side once again.
- ◆ Ensure you are using the correct **holes closer to the center** of the frame, see the second picture. Use the M5 screws to connect extrusions to the frame. Tighten the screws with the 3mm Allen key just slightly!
- ◆ Now, tighten the screws fully, but **IN A DIAGONAL PATTERN**, see the last picture. As soon as you finish tightening the first diagonal pair, tighten the second pair. Then proceed to the other long extrusion.

STEP 4 YZ frame: mounting the shorter extrusions

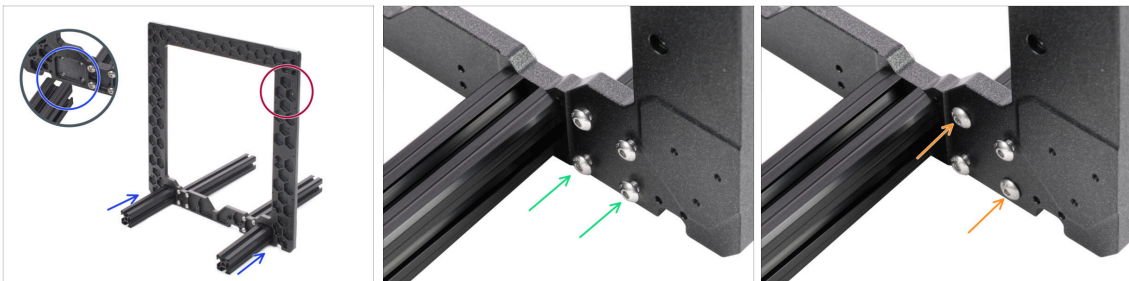

- ◆ Take the **SHORTER** extrusions and place them next to the frame.
- ⚠ **Short extrusions must be placed on the side with the hexagonal recesses.**
- ⓘ Note: screws are inserted from the opposite side of the frame. If you need to manipulate with the frame, make sure the extrusions are on the correct side.
- ◆ Ensure you are using the correct holes, see the second picture. Use the M5x16 screws to connect extrusions to the frame. Tighten the screws just slightly!
- ◆ Now, tighten the screws fully, but **IN A DIAGONAL PATTERN**, see the last picture. As soon as you finish the first diagonal pair, tighten the other screws. Then proceed to the last short extrusion.

STEP 5 YZ frame: final check



⚠ Before we proceed further, let's make a final check. **IT IS VERY IMPORTANT** to have extrusions on the correct side of the frame.

- 🟡 **Long extrusions** - must be mounted to the side of the frame **with the Prusa logo**. Also ensure longer extrusions are **closer together**.
- 🟢 **Short extrusions** - must be on the other side of the frame **without the Prusa logo**. Also ensure shorter extrusions are **further away from each other**.

STEP 6 Y-axis: front and rear plate preparation

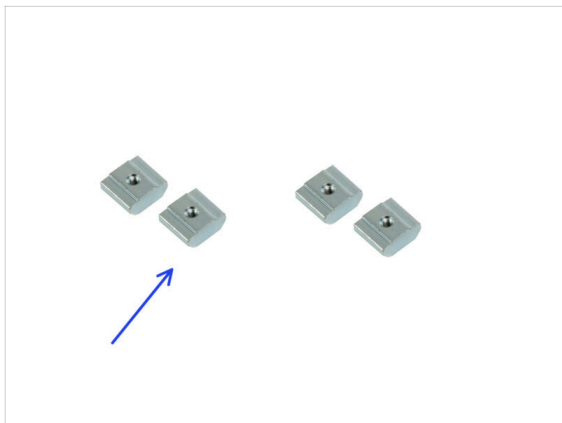
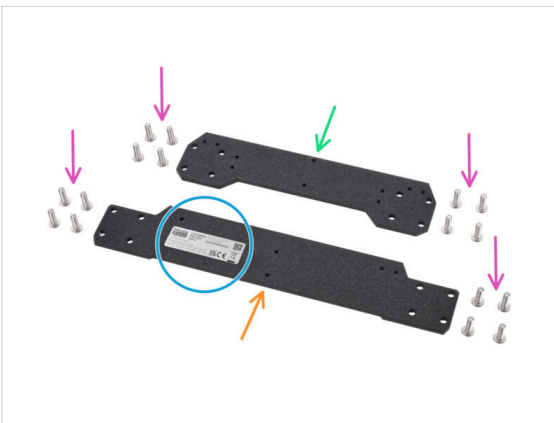

● For the following steps, please prepare:

- 🟢 Front plate (1x)
- 🟡 Rear plate (1x)
- 🟢 There is a sticker with serial number on the rear plate. Keep it in mind, we use it as a guide to orient the part later on. **Do not remove the sticker!**
- 🟡 M5x16r screw (16x)
- 🟢 M3nE nuts (4x)

STEP 7 Y-axis: front plate assembly

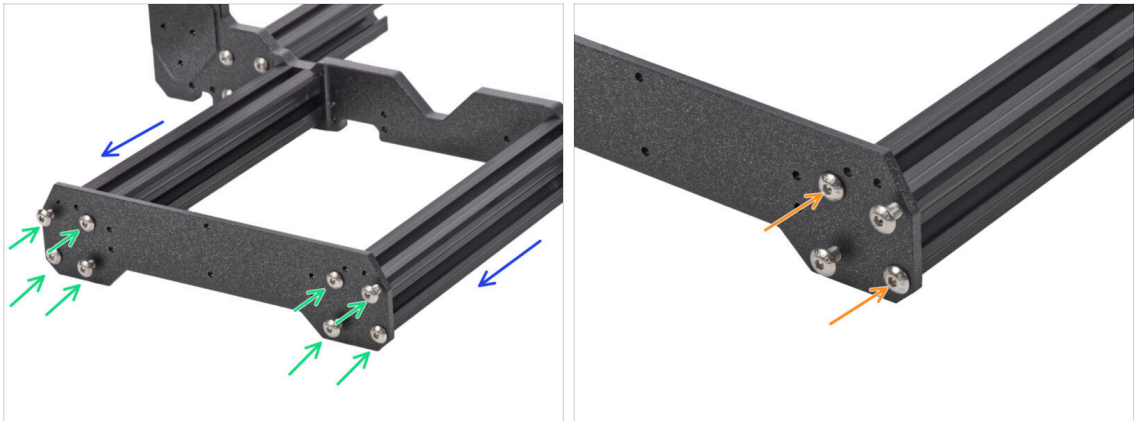

- Rotate the frame so the longer extrusions are facing towards you.
- Place the front plate (the shorter one) onto the extrusions and secure it with M5x16r screws, **DON'T TIGHTEN** them yet!
- Now, tighten the screws fully, but **IN A DIAGONAL PATTERN**, see the second picture. As soon as you finish the first diagonal pair, tighten the second pair. Then proceed to the other long extrusion.

STEP 8 Y-axis: preparation for the PSU and xBuddy-box



- ⚠ **THIS IS AN IMPORTANT STEP!** If the M3nE nuts are placed incorrectly, you will have issues with the assembly later.
- Take the YZ frame and rotate it so the shorter extrusions are facing you.
- Place the M3nE nuts into the groove in the right extrusion - **on the side facing out**. See the picture for a reference.
- Repeat the same for the extrusion on the other side. See the picture.
- ⓘ The exact spacing of the M3nE nuts doesn't matter for now as it will be adjusted later.

STEP 9 Y-axis: rear plate assembly

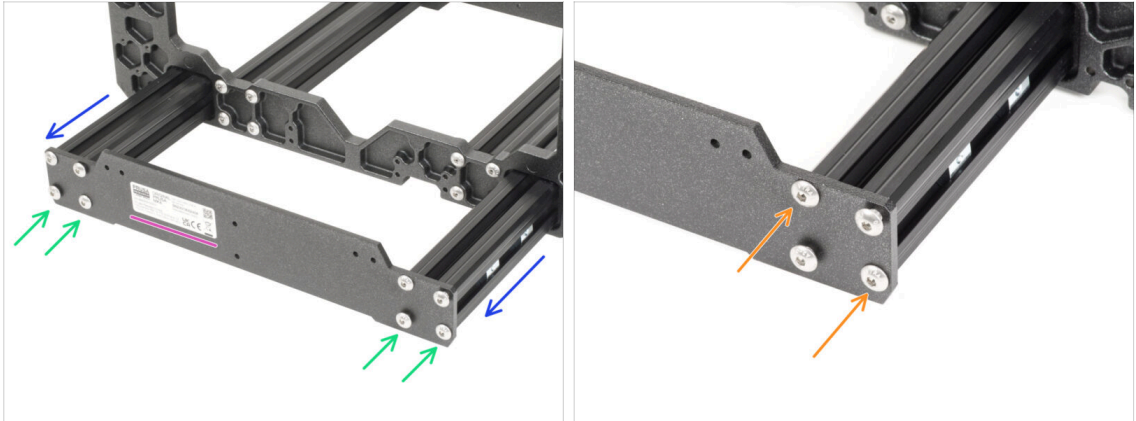

⚠ ATTENTION: Before you install the rear plate, make sure you have inserted M3nE nuts on both sides (two pieces per side)!!!

- 🔵** Ensure the side of the frame with the shorter extrusions is still facing you.
- 🟢** Place the rear plate onto the extrusions and secure it with M5x16r screws, **DON'T TIGHTEN** them yet!
- 🟡** Orient the part so that the sticker is on the back of the printer.
- 🟠** Now, tighten the screws fully, but **IN A DIAGONAL PATTERN**, see the second picture. As soon as you finish the first diagonal pair, tighten the second pair. Then proceed to the other extrusion.

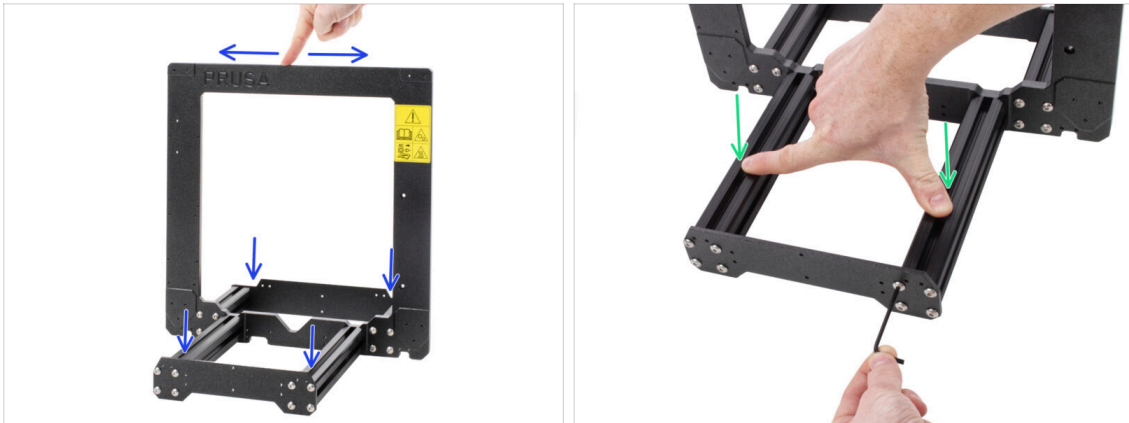
STEP 10 Y-axis: geometry check

⚠ Before you proceed any further, please make sure the frame is standing on a **FLAT SURFACE**.

- The frame screw openings are drilled by a high-precision CNC machine. Uneven tightening during can slightly warp the frame assembly. It can be corrected though.
- Using your hand, try to wiggle the frame side to side to check whether some of the corners are lifting up.
- In case you find any imperfections, release the screws, press the extrusions against the **FLAT SURFACE** and tighten them again. Then check if the frame still rocks side to side, back and forth. **Rotate the whole assembly 90 degrees and check again.** Repeat the whole process if necessary.

⚠ If any of the corners isn't lifting more than 2mm (0.08 inch) high, proceed to the next step.

STEP 11 Mounting antivibration feet and cable clips: parts preparation

● For the following steps, please prepare:

- Antivibration foot (4x)
- Cable clip (7x)

STEP 12 Mounting antivibration feet



- Turn the whole frame assembly onto the side and insert an antivibration foot into the bottom groove of the each extrusion. Insert and turn 90 degrees to lock it in place.
- Repeat this process for all 4 feet. Place them 1-2 cm far from the end of each extrusion.

STEP 13 Installing the cable clips



- Turn the frame like in the picture and focus on the marked area
- Take one of the cable clips and hook the side with the clip into the inner groove of the lower longer extrusion. There is a hook on the part, see the detail.
- Place the other end of the clip on the underside of the extrusion.
- Use more force to push on the bottom side of the cable clip. It must fit into the groove and you must feel it "click" in.

STEP 14 Installing the cable clips



- ◆ Install three clips to the long extrusion.
- ◆ Install two clips to the short extrusion.
- ◆ Turn the frame, install two clips to the second short extrusion.

STEP 15 PSU: parts preparation



- ◆ **For the following steps, please prepare:**
- ◆ Delta PSU 240 W 24 V (1x)
- ◆ M3x10 screw (2x)
- ◆ M4x10r screw with dome head (2x)
- i The PSU (Power Supply Unit) is designed to work worldwide and automatically adapt to the local voltage.

STEP 16 Attaching the PSU



- ◆ Have a look at the right side of the frame and locate the M3nE nuts. Insert M3x10 screws into them. Turn them only 3-4 times by using a 2.5mm Allen key, just for the screws to be kept in place.
- ◆ Take the PSU and place it above the screws. Adjust the M3nE nuts so they line up with the grooves on the bottom of the PSU's case.
- ◆ Slide the PSU down onto the screws. Screw them in some more, but **don't tighten them firmly yet** - we need the PSU to be able to move slightly so we can adjust its position in the next step!
- ⓘ The screws should be able to hold the PSU in a "vertical" position for now.

STEP 17 Attaching the PSU



- ◆ Now have a look at the frame from the front side. Verify the PSU is on the right back side of the frame when looking from the front.
- ◆ Insert M4x10r screws into the holes in the frame, towards the front of the PSU.
- ◆ Adjust the position of the PSU, there are holes in the PSU's case, which must align with the holes in the frame. By default the PSU sits slightly lower than needed, pull it up little bit. until the M4 screws are able to catch the thread in the PSU.
- ◆ Make sure the PSU is pressed against both the frame and the extrusion on the bottom.
- ◆ Everything aligned? Tighten the M4 screws up using the same 2.5mm Allen key.
- ◆ Now, tighten up the M3 screws on the bottom.

STEP 18 xBuddyBox: parts preparation

◆ **For the following steps, please prepare:**

- ◆ xBuddy box (1x)

ⓘ xBuddy box is located in the box with plastic parts.

- ◆ Thermal pad 40x12x2.2 mm (1x)

- ◆ Thermal pad 12x12x2.2 mm (2x)

- ◆ M3x6 screw (9x)

- ◆ M3x10 screw (2x)

ⓘ The list continues in the next step...

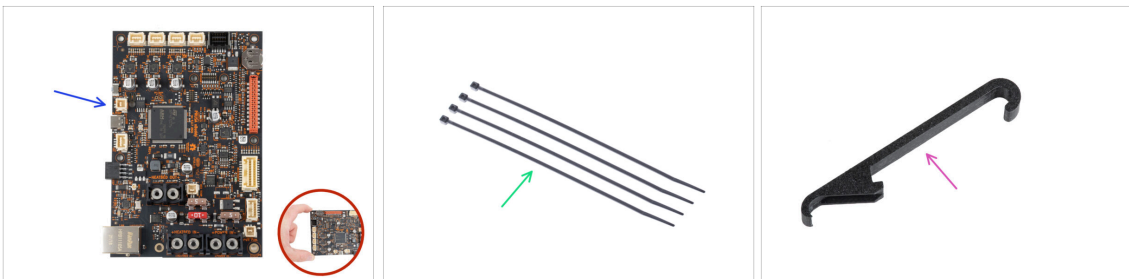
STEP 19 Mounting the xBuddyBox: parts preparation

◆ **For the following steps, please prepare:**

- ◆ xBuddy Board (1x)

⚠ **Always touch the sides of the electronics board while manipulating it. Avoid touching the chips, capacitors and other parts of the electronics.**

- ◆ Zip tie (4x)

- ◆ X-holder (1x)

STEP 20 Mounting the xBuddyBox



- Insert four M3x6 screws to the back of the frame (side with shorter extrusions), so they resemble a rectangular pattern. Tighten the screws fully into the frame to clean the threads. Then loosen the screws, **leaving a gap of at least 3 mm between the screw head and the frame.**
 - ⚠ **Make sure you are using the correct holes.**
- Insert two M3x10 screws into the M3nE nuts in the second short extrusion. Turn them only 3-4 times by using a 2.5mm Allen key, just for the screws to be kept in place.

STEP 21 Mounting the xBuddyBox

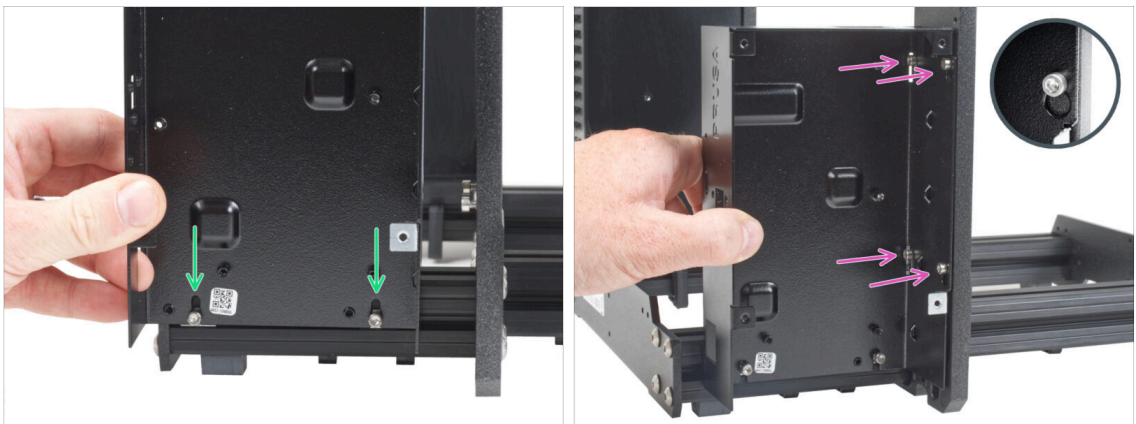

- Attach the xBuddyBox on the M3x10 screws in the extrusion. **Do not tighten the screws at the moment!**
- Slide the xBuddyBox to the frame and attach the box to all 4 screws in the frame. The screws must fit into the top part of the "key" hole. See the detail.

STEP 22 Mounting the xBuddyBox

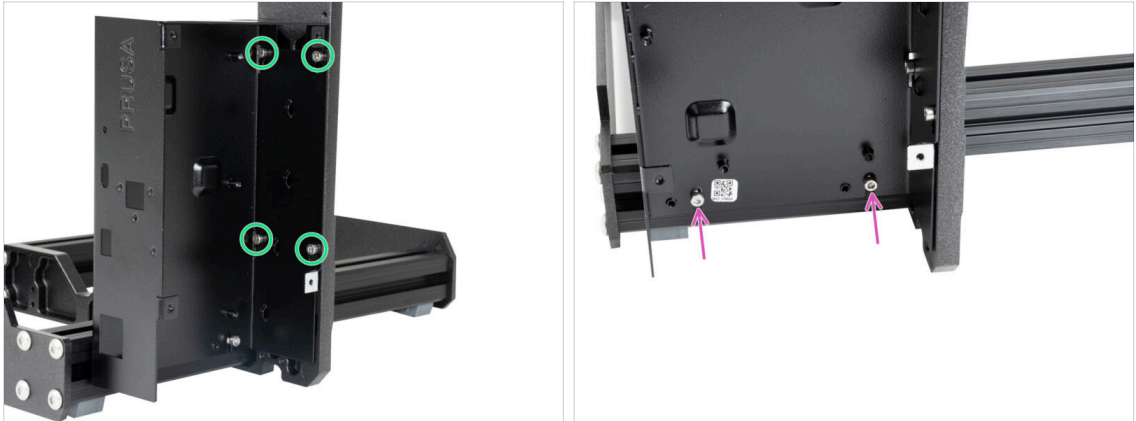

- Fully tighten all four M3x6 screws to secure the xBuddyBox.
- ⓘ Be careful when tightening the "rear" top screw. Use the shorter side of the Allen key for final tightening.
- Fully tighten both M3x10 screws in the M3nE nuts.

STEP 23 Applying the thermal pads

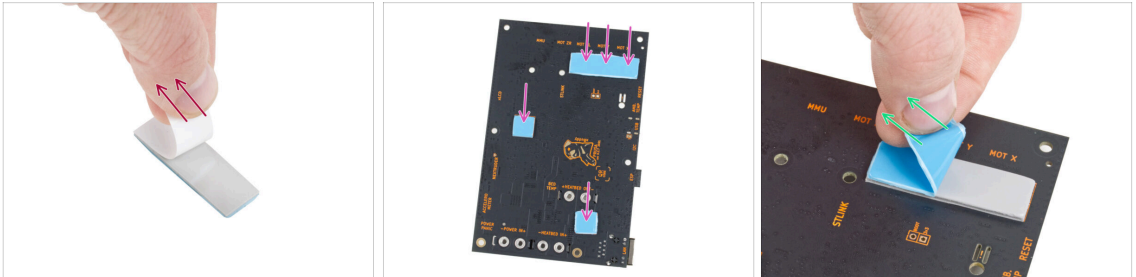

- Peel off the white protective layer from all thermal pads.
- ⚠ **Always touch the sides of the electronics board while manipulating it. Avoid touching the chips, capacitors and other parts of the electronics.**
- Attach the pads onto the back of the xBuddy board. There are markings that indicate the correct size and positions.
- ⓘ The surface to which the pads are stuck must be cleaned of grease. This will ensure better adhesion.
- ⚠ **For the protection of the board's electronic components, we strongly recommend placing the xBuddy board on the soft pad. You can use the original xBuddy bubble wrap package.**
- Peel off the blue protective layer from all thermal pads.

STEP 24 Mounting the xBuddy board



- ◆ For better access to the xBuddy box, carefully place the frame on the side with the PSU.
- ◆ Insert the xBuddy board into the xBuddy Box. **Before fully attaching it completely, center the holes** in the board with the holes (columns) in the xBuddy Box
- ◆ Fix the position of the xBuddy Board by inserting **five M3x6 screws**. **Do not fully tighten the screws**. A few turns are enough for now.
 - ⚠ **Put aside your instinct and leave the hole on the bottom right empty.**
- ◆ Fully tighten all five screws. **But very carefully**, otherwise you can damage the electronics board.

STEP 25 Attaching the zip ties

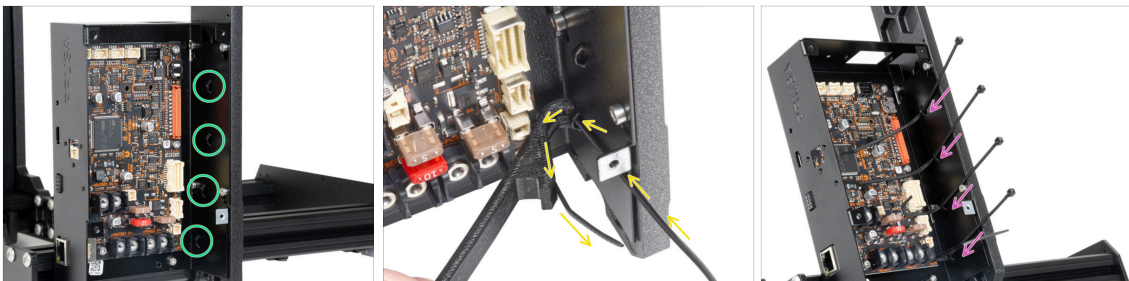

- ◆ Take a closer look at to the xBuddy box. There are four perforations on the metal case.
- ⓘ You can place the frame on the PSU side for better access to the xBuddy box.
- ⚠ **Proceed very carefully. Be careful not to damage the connectors or capacitors on the xBuddy board.**
- ◆ Use the X-holder as a zip tie guidance. Place the X-holder behind the lowest perforation like in the picture. Push the zip tie through the protrusion to the X-holder. Keep protruding 3 - 5 cm of the zip tie from the perforation.
 - ⚠ **Note the correct orientation of the zip tie. The teeth on the zip tie must be on the visible side.**
- ◆ Use this procedure for all four protrusions.
- ⚠ **Do not discard the X-holder. You will need it later again.**
- ◆ Place the printer back on its "feet".

STEP 26 Preparing Y-belt-idler (part 1)

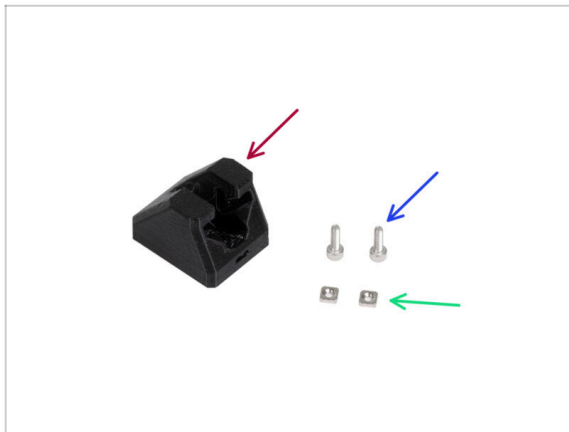

- Y-belt-idler (1x)
- M3x10 screw (2x)
- M3nS nut (2x)

STEP 27 Preparing Y-belt-idler (part 2)



- Insert two M3nS nuts into the Y-belt-idler.
- ⓘ There is a groove in the hole for pushing the nut all the way in with an Allen key.

STEP 28 Mounting the Y-belt-idler

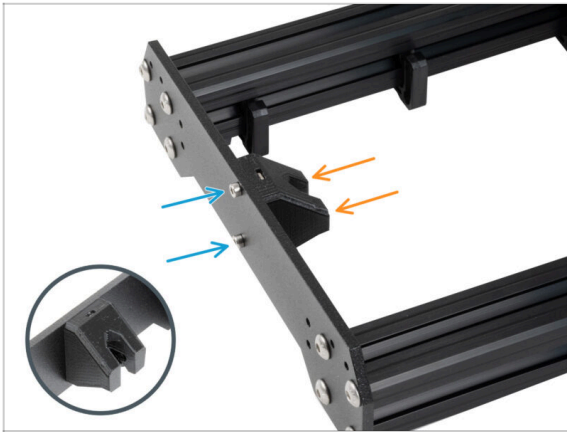

- Arrange the frame so that the longer extrusions are facing you.
- Attach the Y-belt-idler from "inside" to the front plate. **Note the correct orientation of the part.**
- Secure the Y-belt-idler with two M3x10 screws.

STEP 29 Assembling the Y motor: parts preparation

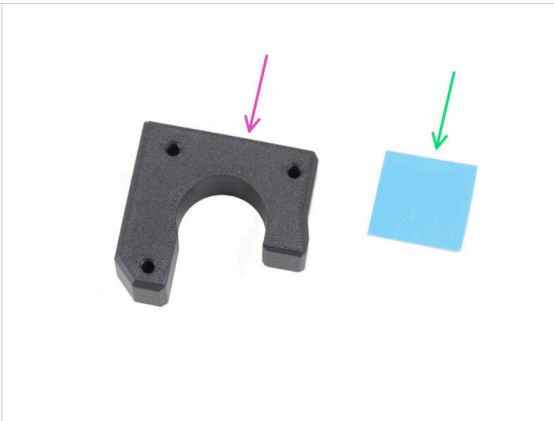

- **For the following steps, please prepare:**
- Y-motor-holder (1x) (looks slightly different, than this picture)
- Thermal pad 25 x 25 x 1.2 mm(1x)
- M3x18 screw (3x)
- M3x10 screw (2x)
- M3nS nut (2x)
- **i** The list continues in the next step...

STEP 30 Assembling the Y motor

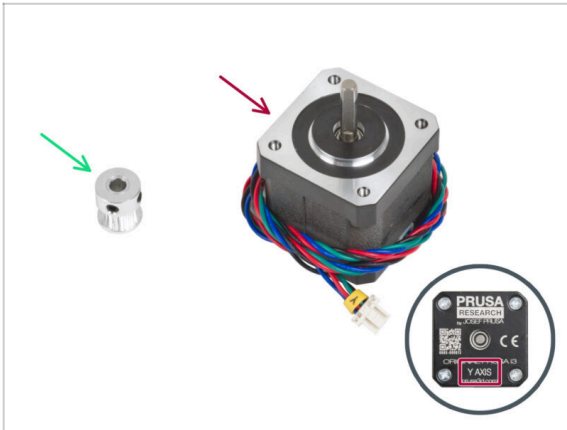

◆ For the following steps, please prepare:

◆ Y motor (1x)

⚠ **Ensure you are using the correct motor**, there is a label on the bottom of the casing. The reason is, each motor has different cable length.

◆ GT2-16 pulley (1x)

STEP 31 Assembling the Y-motor-holder

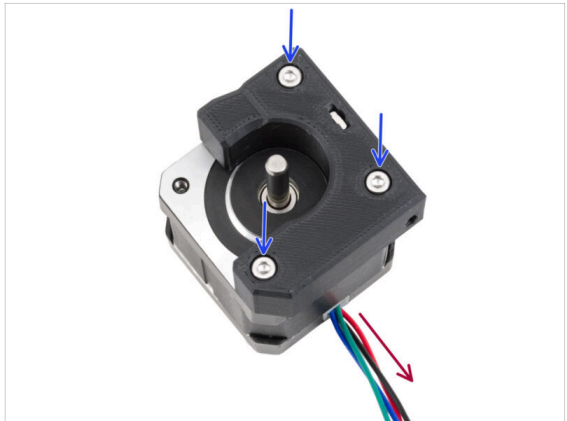

- ◆ Insert two M3nS nuts into the corresponding openings on the inside of the Y-motor-holder
- ◆ Place the Y motor like in the picture. Use the motor cable as a guide.
- ◆ Attach the Y-motor-holder onto the Y motor and join both parts together with three M3x18 screws.

STEP 32 Assembling the Y-motor-holder

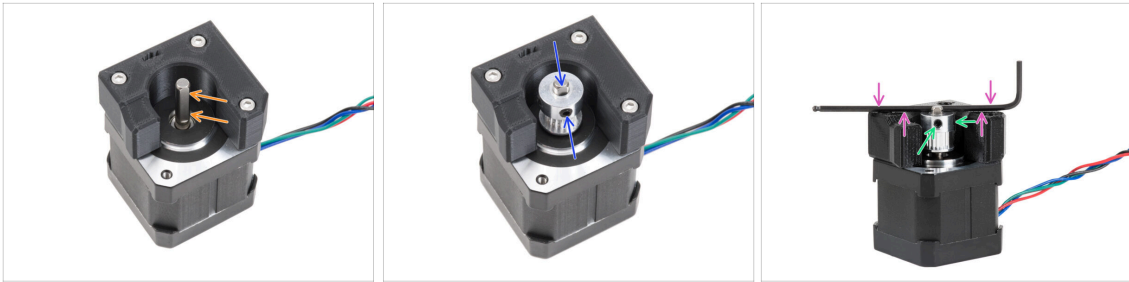

- ◆ There is a flat part on the motor shaft. Rotate the shaft, so the flat part is facing you though the opening in the Y-motor-holder.
- ◆ Attach the pulley on the shaft and ensure that one of the grub screws is facing the flat part of the shaft. **Do not tighten the grub screw yet.**
- ⚠ **Note the CORRECT ORIENTATION of the pulley.**
- ◆ Put one of the Allen keys on the **TOP surface** of the printed part, like in the picture. And align the pulley with the Allen key.
- ◆ When the pulley is aligned, tighten the grub screw in the pulley against the flat part of the **shaft**. **Then rotate the pulley and tighten the second grub screw.**

STEP 33 Attaching the Y-motor-holder

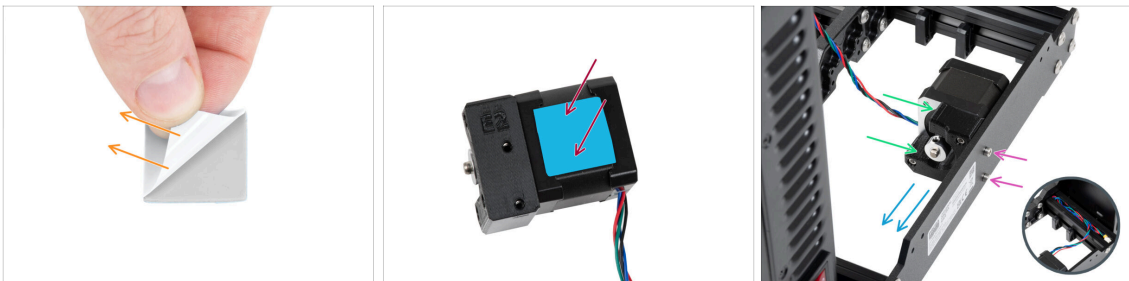

- ◆ Peel off the white protective film from the thermal pad 25x25x2.2 mm on the Y motor.
- ⓘ The side with the white film is more adhesive. If you have a thermal pad with a blue protective film on both sides, the side doesn't matter.
- ◆ Stick the thermal pad on the Y motor and **peel off the second protective layer** from it.
- ⓘ The surface to which the pad is stuck must be cleaned of grease. This will ensure better adhesion.
- ◆ Place the Y-motor-holder onto the inner side of the rear plate of the frame.
- ◆ Ensure the correct orientation. The pulley must be facing towards the PSU.
- ◆ Attach the Y-motor-holder by using two M3x10 screws.
- ◆ To keep the Y motor cable safe during the assembly, temporarily hide it in the extrusion on the xBuddy box side.

STEP 34 Haribo

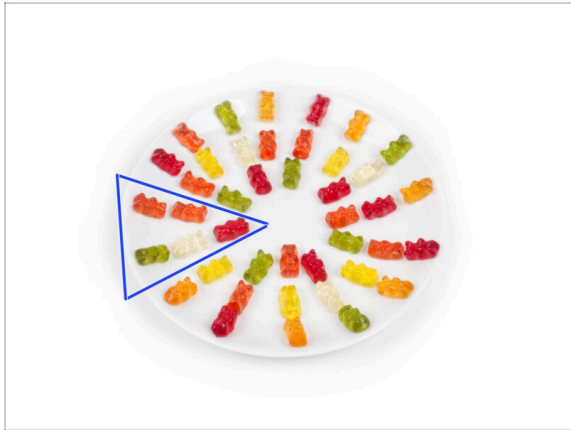

⚠ Carefully and quietly open the bag with the Haribo sweets. High level of noise might attract nearby predators!

- ◆ Spread the entire contents of the bag on a clean plate and arrange them according to the picture. The color doesn't matter that much.
- ⓘ The total number in your package may vary slightly. However, the exact number is important. If any gummy bears are missing, please go to your nearest candy store immediately.
- ◆ Eat five gummy bears.
- ⓘ **Did you know that** gummy bears were first created by a German candy maker named Hans Riegel in the 1920s.

STEP 35 It's done!



- ◆ Compare the final look of the assembly with the picture.
- ◆ So that was an easy start, wasn't it? Good job anyway!
- ◆ Now, let's play with the next chapter: **3. X-axis & X-carriage assembly**

3. X-axis & X-carriage assembly



STEP 1 Tools necessary for this chapter

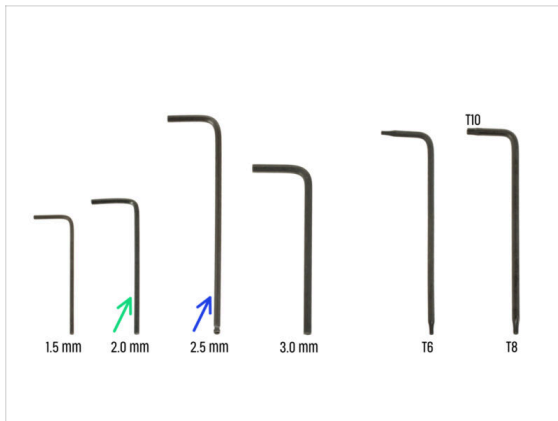

- **For this chapter, please prepare:**
- 2.0mm Allen key
- 2.5mm Allen key
- Permanent marker (*not included in the kit*)

STEP 2 X-axis assembly: parts preparation

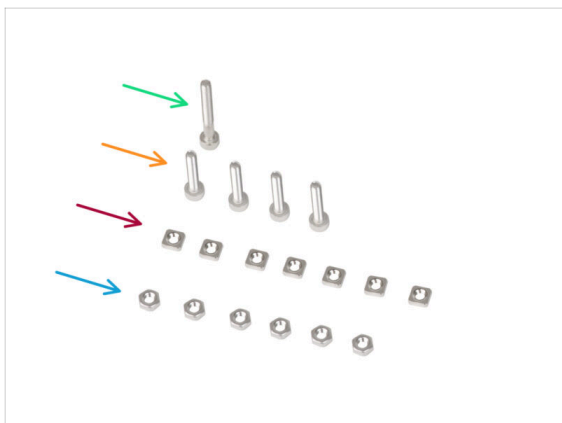
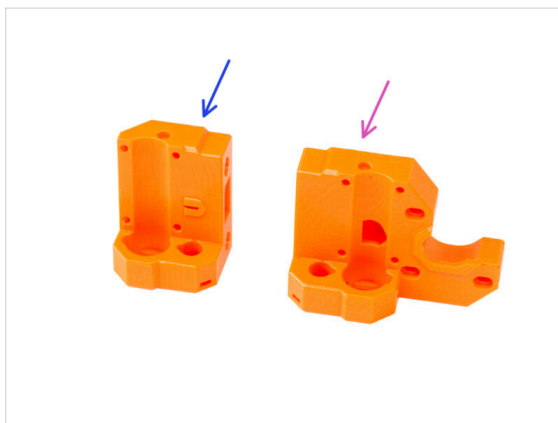

- **For the following steps, please prepare:**
- X-end-idler (1x)
- X-end-motor (1x)
- M3x25 screw (1x)
- M3x16 screw (4x)
- M3nS nut (7x)
- M3n nut (6x)

STEP 3 Assembling the X-end-motor



- Insert four M3n nuts into the holes on the backside of the X-end-motor.
 - ⓘ Use the screw pulling technique.
- Insert and tighten the M3nS nut into the plastic part.
- Screw the M3x25 screw into the plastic part. Do not tighten the screw completely. Keep the screw head aligned with the top surface of the part.
- From the "bottom" side of the part, insert and tighten the M3x16 screw.
- ⚠ **Make sure you are using the correct length of the screw. If you're not sure, always compare the dimensions of the screws with the cheatsheet.**
- Insert and tighten one M3x16 screw from the "top" side of the part.

STEP 4 Assembling the X-end-motor



- From inside the oval opening, insert the M3nS nut into the X-end-motor.
- From the side, insert the second M3nS nut into the part.
- ⚠ **Do not put too much pressure on the nut to avoid damaging the opposite printed wall.**

STEP 5 Assembling the X-end-idler

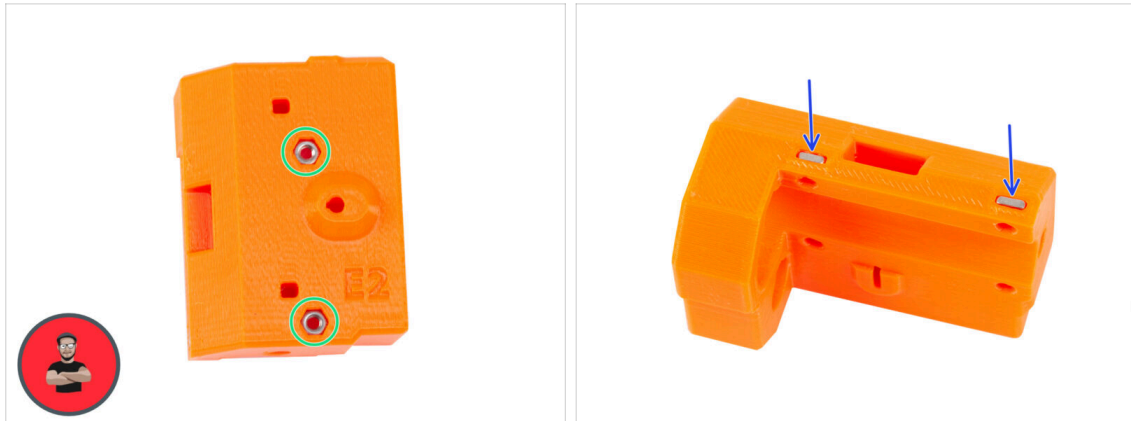

- Insert two M3n nuts into the holes on the backside of the X-end-idler.
 - ⓘ Use the screw pulling technique.
- Insert two M3nS nut from the side to the plastic part.

STEP 6 Assembling the X-end-idler

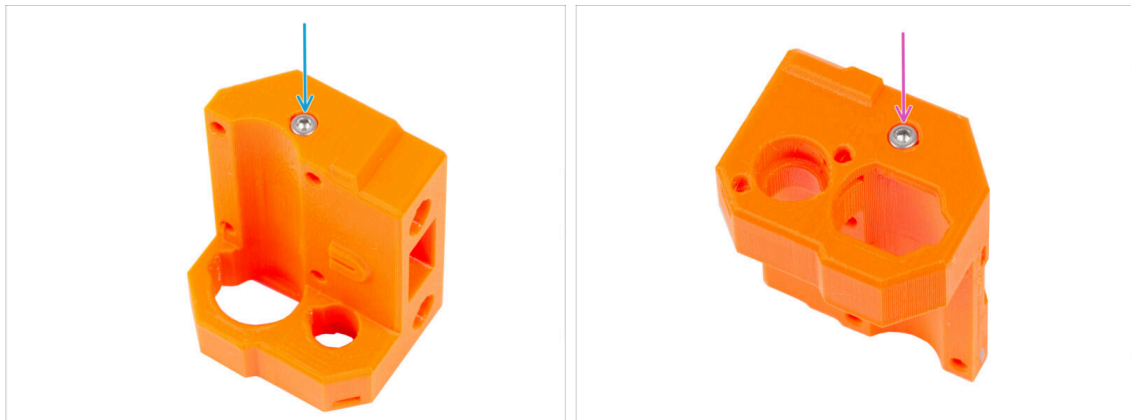

- ⚠ **Make sure you are using the correct length of the screw M3x16, not M3x18. If you're not sure, always compare the dimensions of the screws with the cheatsheet.**
- From the "bottom" side of the part, insert and tighten the M3x16 screw.
- Insert and tighten the second M3x16 screw from the "top" side of the part.

STEP 7 Assembling the X-end-idler

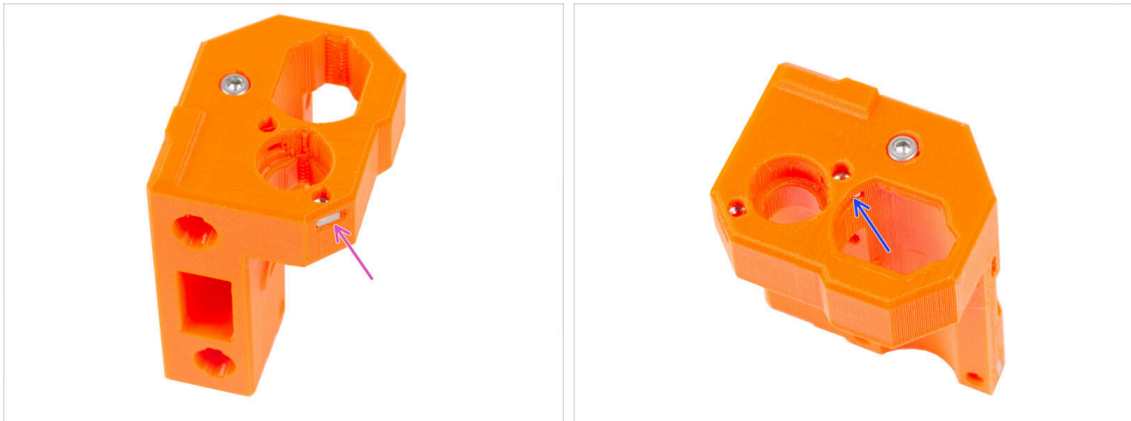

◆ Insert the M3nS nut into the X-end-idler from the side.

⚠ Do not put too much pressure on the nut to avoid damaging the opposite printed wall.

◆ From inside the oval opening, insert the M3nS nut into the X-end-idler.

STEP 8 Mounting the bearings: parts preparation

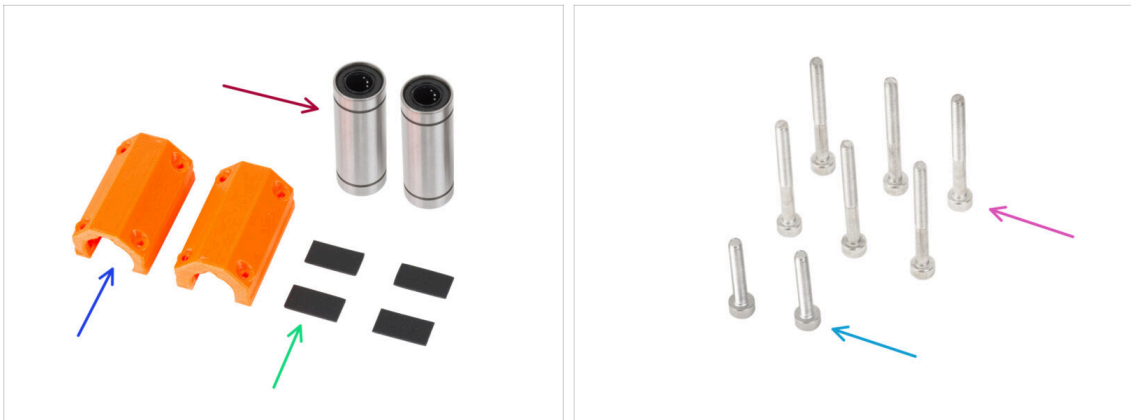

◆ For the following steps, please prepare:

◆ LM10UU linear bearing (2x)

◆ X-end-clip (2x)

◆ Rubber pad 20x10x1 mm (4x)

◆ M3x30 screw (6x)

◆ M3x18 screw (2x)

STEP 9 Mounting the bearings: parts preparation (lubricating)

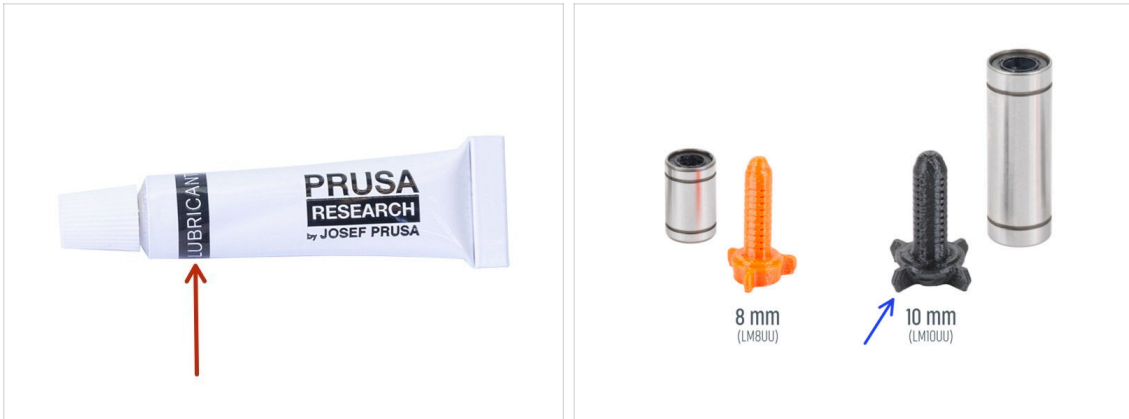

● For the following steps, please prepare:

● Prusa lubricant (1x)

● Prusa lubricant applicator 10mm (1x) for LM10UU bearings

ⓘ There are two versions of the Prusa lubricant applicator in your kit. Each with a different size.

● Several paper towels to wipe oil and grease from the bearing surface.

⚠ **Each bearing must be lubricated before mounting on the printer. Follow these instructions carefully.**

⚠ **Use the lubricant wisely, less is better!** The lubricant will be used for all bearings and gearbox. The amount in the tube is sufficient. Follow the instructions regarding proper amount for each bearing. Using too much of the lubricant can cause issues.

STEP 10 Lubricating the bearing



ⓘ Use any piece of fabric as a pad to protect your working surface from grease.

⚠ **Make sure the bearing is clean inside.**

● Wipe the preservative oil off the bearing surface with a paper towel.

● It is necessary to lubricate all 4 rows of balls inside the bearing.

● Open the lubricant and pierce the hole in the tube with the tip in the cap.

● Screw the tube into the applicator.

● Carefully slide the entire bearing onto the applicator.

STEP 11 Lubricating the bearing



- Turn the tube and applicator clockwise until you feel a slight resistance. This means that the holes in the applicator are aligned with the ball rows.
- Gently press the tube to push the lubricant into the ball rows of the bearing.
- Remove the bearing from the applicator and look at the amount applied inside. Take a look at the third picture, which shows a sufficient amount of lubricant inside the bearing.
- ⚠ **The grease must be spread evenly over all four ball rows inside the bearing. There must not be too much grease, a thin layer is enough. Take a closer look at the last picture.**
- **Proceed the same from the opposite side of the bearing. The lubricant in the LM10UU bearing must be applied along its entire length.**
- Wipe off excess grease on the outside of the bearing with a paper towel.
- Use this procedure for both LM10UU bearings.

STEP 12 Inserting the bearings: X-end-motor



- Insert and push one LM10UU bearing all the way into the X-end-motor.
- Position the bearing like in the picture. The ball rows must be oriented to "X".

STEP 13 Inserting the bearings: bearing pads



- Take one X-end-clip. Notice, there are two rectangular pockets inside the plastic part.
- Place the rubber pads into both pockets by pushing the finger on them.
- Apply the same procedure for both X-end-clips.

STEP 14 Covering the bearings: X-end-motor

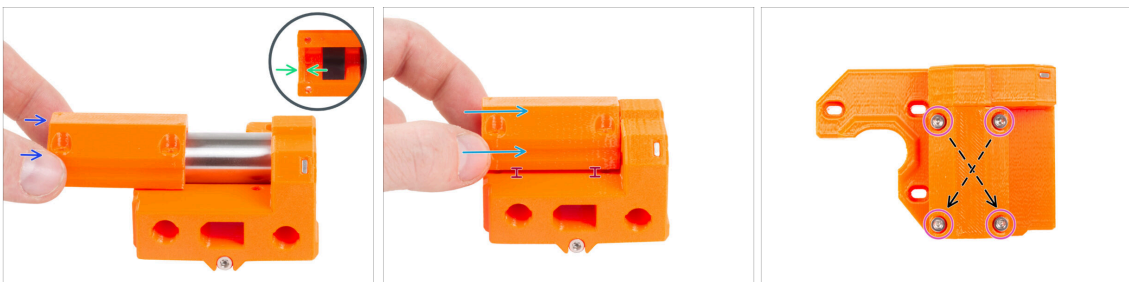

- Place the X-end-motor with the bearing as shown.
- Take the X-end-clip and notice the protrusion on the inside of the part. The protrusion must be behind the edge of the bearing (pictured on the left side of the bearing).
- In this position, slide the X-end-clip onto the edge of the bearing.
- Very carefully slide the X-end-clip onto the entire length of the bearing.
- ⚠ Hold the X-end-clip slightly raised from the bottom surface of the X-end-motor. Pushing on the X-end-clip from the top may deform the rubber pads inside the part.
- Insert four M3x30 screws into the X-end-clip. Tighten the screws diagonally.
- Tighten the screws completely, **but diagonally**.

STEP 15 Inserting the bearings: X-end-idler

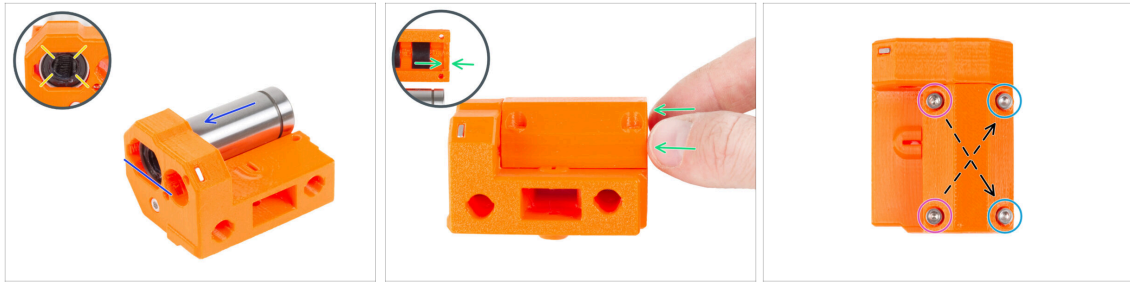

- Insert and push the second LM10UU bearing all the way into the X-end-idler.
- Position the bearing like in the picture. The ball rows must be oriented to "X".
- Slide the remaining X-end-clip onto the bearing in the same way as in the previous step. Do not forget to orient the part correctly.
- **There are two types of the screws for the X-end-clip on the X-end-idler:**
 - Insert two M3x30 screw into the holes on the **left side**.
 - Insert two M3x18 screws into the holes on the **right side**.
 - Tighten the screws completely, **but diagonally**.

STEP 16 Assembling the X-axis: parts preparation

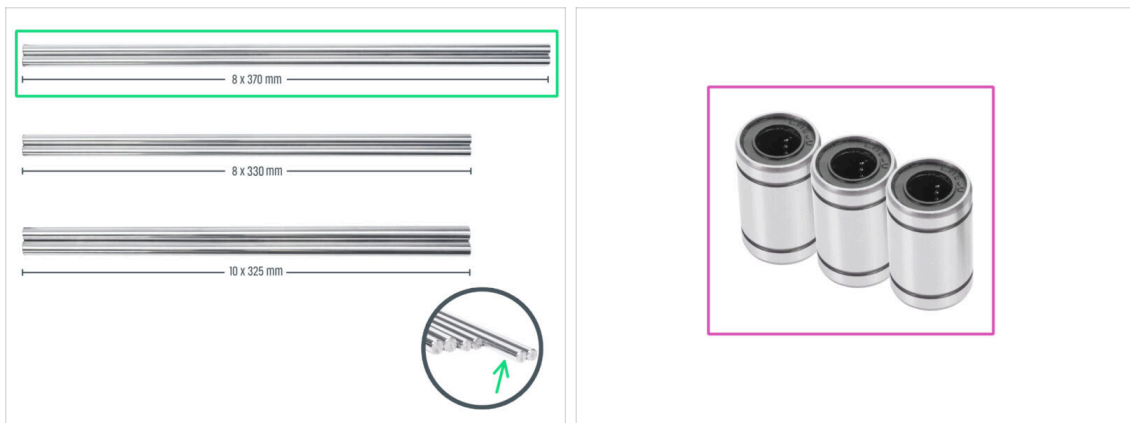

- **For the following steps, please prepare:**
- ⚠ **Notice that you have received three different lengths of smooth rods. We recommend arranging them all side by side, for easier comparison of their sizes.**
- Smooth rod 8x370 mm (2x) *the longest couple*
- ⓘ Wipe off the preservative oil from the smooth rods with a paper towel or a piece of cloth.
- LM8UU bearing (3x)

STEP 17 Assembling the X-axis: Marking the bearings

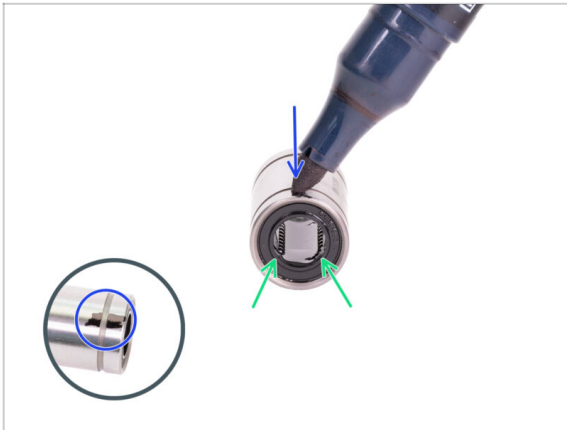

- Wipe grease from the outer surface of the bearing with a paper towel.
- Position the bearing so that you can see two rows of balls. Like in the picture.
- Make a mark with a permanent marker on the outer surface of the bearing, in the middle above two rows of balls.
- Use the same procedure for the remaining two bearings.
- ⓘ We will use these markings in the upcoming chapters to achieve the desired bearing orientation.

STEP 18 Assembling the X-axis: parts preparation (lubricating)



● **For the following steps, please prepare:**

- Prusa lubricant applicator 8mm (1x)
- Prusa lubricant (1x) for LM8UU bearings
- Several paper towels to wipe oil and grease from the bearing surface.

⚠ **Each bearing must be lubricated before mounting on the printer. Follow these instructions carefully.**

STEP 19 Lubricating the bearing



i Use any piece of fabric as a pad to protect your working surface from grease.

! **Make sure the bearing is clean inside.**

- ◆ Wipe the preservative oil off the bearing surface with a paper towel.
- ◆ It is necessary to lubricate all 4 rows of balls inside the bearing.
- ◆ Screw the tube into the applicator.
- ◆ Carefully slide the entire bearing onto the applicator.

STEP 20 Lubricating the bearing



- ◆ Turn the tube and applicator clockwise until you feel a slight resistance. This means that the holes in the applicator are aligned with the ball rows.
- ◆ Gently press the tube to push the lubricant into the ball rows of the bearing.
- ◆ Look at the front of the bearing. When the applicator pushes the lubricant out (around the black gasket), stop pressing the tube. Hold the bearing with the other hand during the lubricating.
- !** **The grease must be spread evenly over all four ball rows inside the bearing. There must not be too much grease, or too little. Take a closer look at the last picture.**
- ◆ Wipe off excess grease on the outside of the bearing with a paper towel.
- ◆ Use this procedure for all three bearings.
- i** The bearings may leave excess grease on the smooth rods after their installation. Wipe off any residue with a paper towel.

STEP 21 Assembling the X-axis: Inserting smooth rods

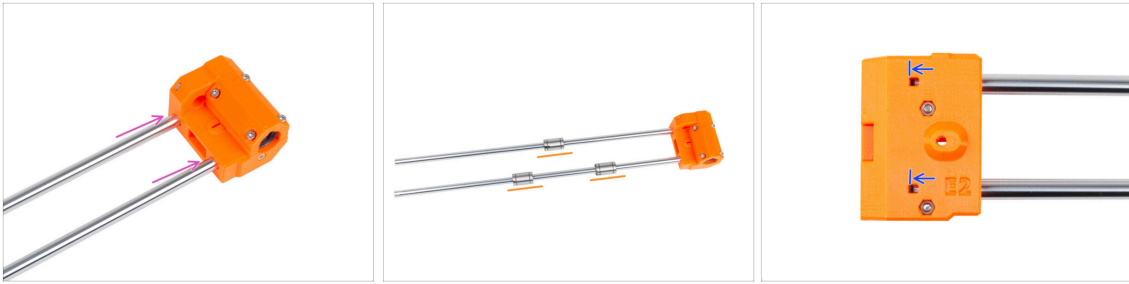

- ✿ Insert the smooth rods all the way into the X-end-idler.
- ⚠ **Insert the rods very carefully. Do not tilt the rods too much.**
- 🔸 **Carefully and gently** slide three bearings onto the smooth rods. One bearing on the upper rod and two bearings on the lower rod. See the picture. Orientation of the markings doesn't matter at this moment
- 📄 In case you manage to push out balls from the bearings, please count them. One or two balls are ok, if there are more of them, please consider ordering new bearings.
- 🔹 Through the inspection hole check if the smooth rods are in touch with the screws inside the part.

STEP 22 Assembling the X-axis: mounting the X-end-motor

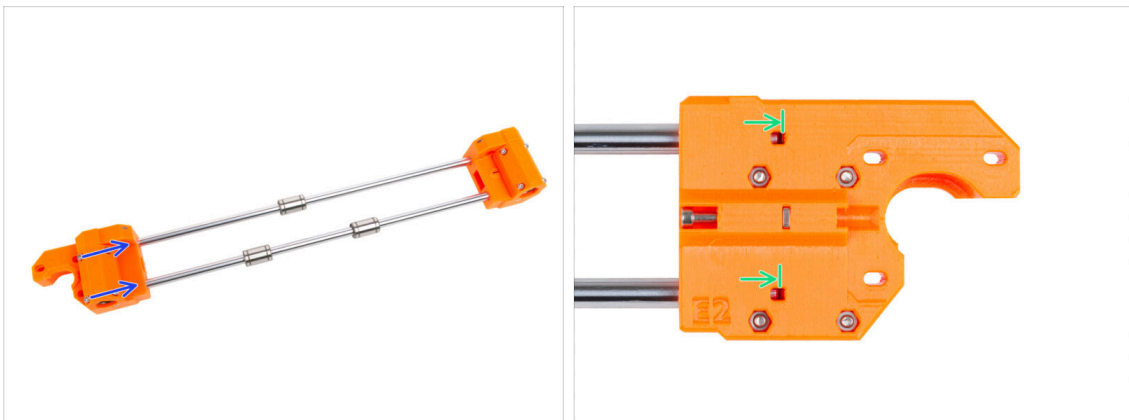

- 🔹 Carefully slide the X-end-motor fully onto both smooth rods.
- 🟢 Through the inspection hole check if the smooth rods are in touch with the screw.

STEP 23 Assembling the X-carriage: parts preparation

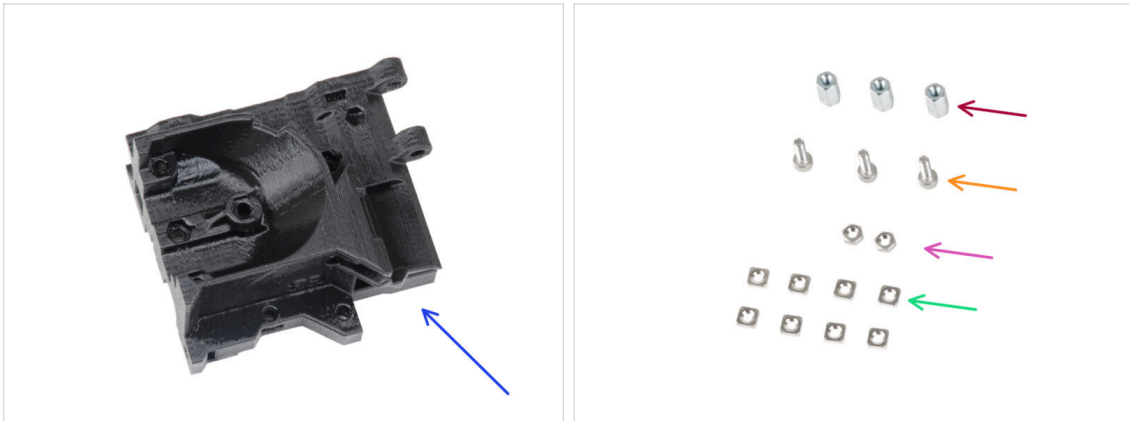

● For the following steps, please prepare:

- X-carriage (1x)
- Hex spacer M3x10 (3x)
- M3n nuts (2x)
- M3x10 screw (3x)
- M3nS nut (8x)

STEP 24 Assembling the X-carriage



- Locate the protrusions on the X-carriage part and insert three M3nS nuts into the square holes.
- From the "bottom" of the part, insert five M3nS nuts into the part.

STEP 25 Attaching the spacers

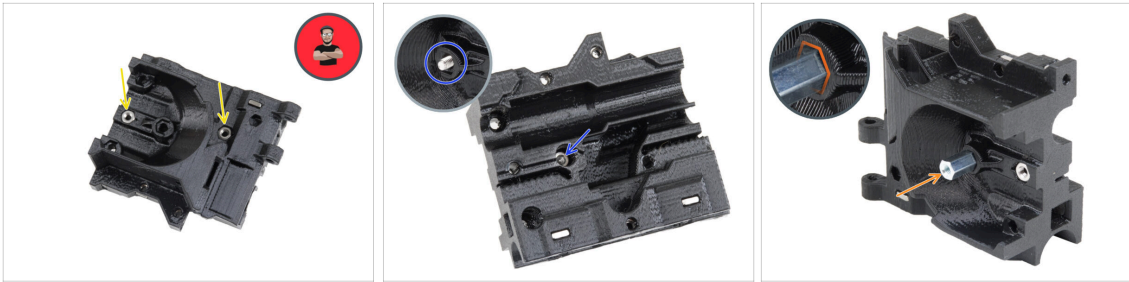

- ◆ Insert two M3n nuts to the X-carriage-back.
 - ⓘ Use the screw pulling technique.
- ◆ From the opposite side, insert the M3x10 screw into the X-carriage-back. The screw must protrude from the "front" side of the part.
- ◆ Attach the hex spacer on the M3x10 screw and tighten the screw. **Note the cutout of the same shape as the spacer. It must fit perfectly and must not rotate.**

STEP 26 Attaching the spacers



- ◆ Push two M3x10 screws through the X-carriage
- ◆ From the "front" side of the X-carriage, attach two hex spacers on the protruding M3x10 screws in the same way described in the previous step. Tighten the screws.

STEP 27 Assembling the X-carriage-clip: parts preparation

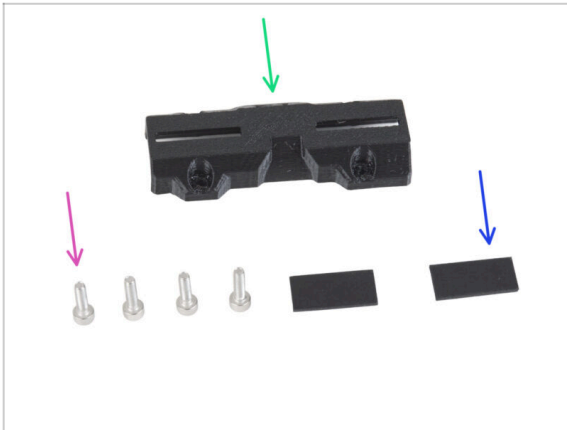

● For the following steps, please prepare:

- X-carriage-clip (1x)
- M3x10 screw (4x)
- Rubber pad 20x10x1 mm (2x)

STEP 28 Assembling the X-carriage-clip



- Place two rubber pads into the rectangular pockets inside the X-carriage-clip.

STEP 29 Attaching the X-carriage-clip



- **Place the X-axis assembly oriented as shown.** Make sure the back of the X-end-motor is facing up.
- Attach the X-carriage on both bearings on the lower rod. See the orientation of the X-carriage-motor on the picture.
- Leave the upper bearing out of the X-carriage for the time being.
- Slide both lower bearings all the way into the pockets in the X-carriage and align them with the outer surface of the X-carriage.
- Rotate both bearings so that the marking is facing you (down).
- Cover the bearings with the X-carriage-clip and secure it by four M3x10 screws. **Do not fully tighten the screws at the moment.**

STEP 30 Attaching the X motor: parts preparation

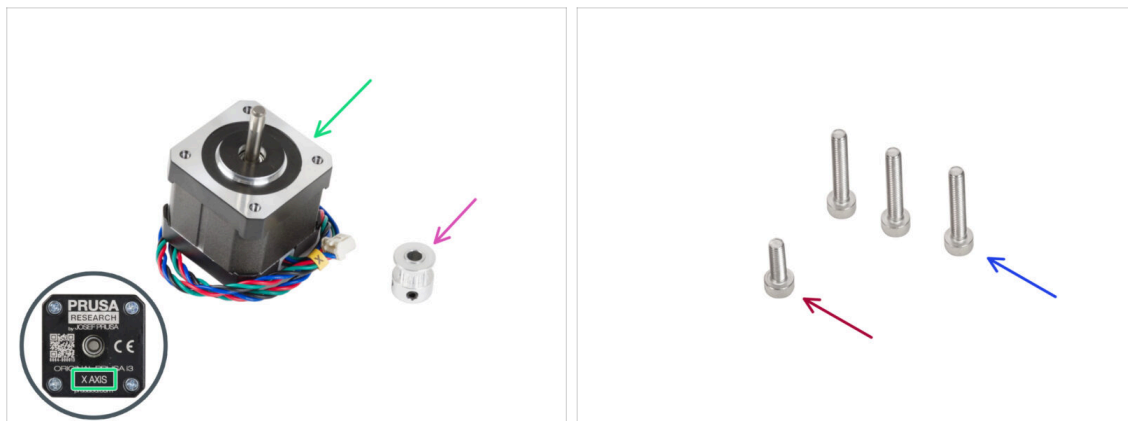

For the following steps, please prepare:

X motor (1x)

⚠ **Ensure you are using the correct motor, there is a label on the bottom of the casing. The reason is, each motor has different cable length.**

GT2-16 pulley (1x)

M3x18 screw (3x)

M3x10 screw (1x)

STEP 31 Attaching the X motor

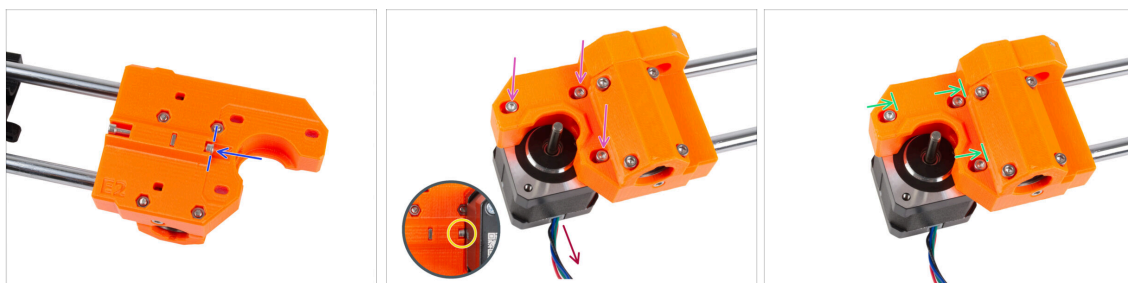

Insert the M3x10 screw into the X-end-motor. Line up it with the edge of the plastic protrusion. Do not tighten the screw, there is no thread inside, just insert it freely.

Place the X-end-motor on the X motor. Secure it by three M3x18 screws. **Tighten the screws just slightly.** We will adjust them later on.

⚠ **Note the correct X motor orientation. The cable must be facing you.**

Make sure that the "tension" screw on the X motor side does not fall out during handling.

Position the motor so that the screws are at the inner end of the oval holes.

STEP 32 Attaching the X motor: mounting the pulley

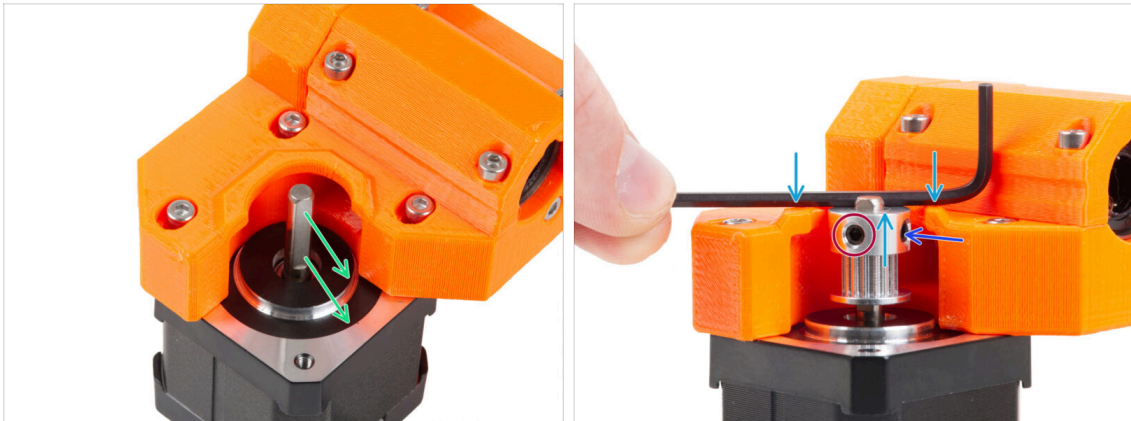

- ◆ There is a flat part on the motor shaft. Rotate the motor shaft with the flat part facing through the opening in the X-end-motor.
- ⚠ Slide the Pulley on, note the **CORRECT** orientation. Compare it with the second picture!
- ◆ Place any of the Allen keys on the top surface, like in the picture and align the pulley with the Allen key.
- ◆ **One of the grub screws must be facing directly against the flat part of the shaft.** Slightly tighten the grub screw.
- ◆ Rotate the pulley and tighten the second grub screw.

STEP 33 Guiding the X belt: parts preparation



- ◆ **For the following steps, please prepare:**
- ◆ X belt (1x)
- ◆ Pin H8 3x20 (1x)
- ◆ GT2-20 Idler pulley (1x)

STEP 34 Guiding the X belt: X-end-idler



- Guide the X belt around the Idler pulley.
- Insert the "clamped" pulley with the belt inside the X-end-idler.
- Align the hole in the pulley with the left hole in the plastic part.
- After aligning the pulley, push the pin through the plastic part and the pulley. Push the pin all the way in using the Allen key.
- Pull lightly on the belt to secure the position of the pulley. You will see the pin in the hole slide inside the part. Once the pulley is secured, the pin is not visible at all.

STEP 35 Guiding the X belt: X-end-motor

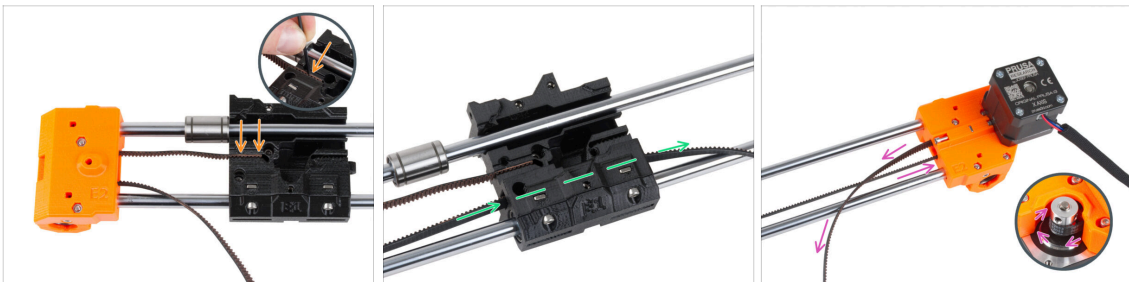

- i** Leave the upper bearing free for now.
- Insert the "upper" end of the belt into the groove in the X-carriage. Push it all the way in using the Allen key.
- Push the "lower" end of the belt through the belt channel in the X-carriage.
- Guide the belt through the X-end-motor around the pulley and back to the X-carriage.

STEP 36 Guiding the X belt: X-carriage

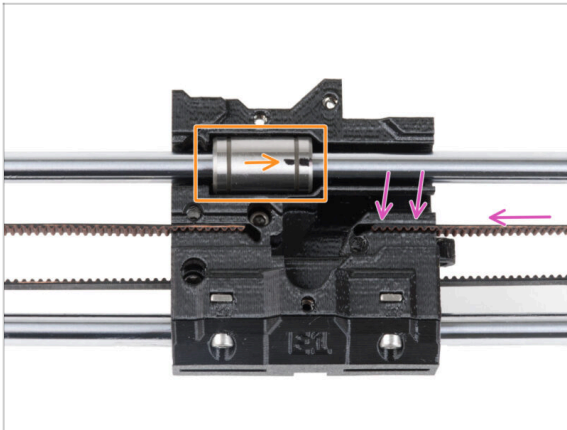

- ◆ Guide the X belt to the X-carriage and push it to the groove in the plastic part as far as possible. Push it all the way in using the Allen key.
- ⓘ The belt must not be too loose (sagging). We will adjust its tension later.
- ◆ Place the upper bearing into the recess in the X-carriage. The marking must be facing you, like in the picture.

STEP 37 Assembling the X-carriage: final check

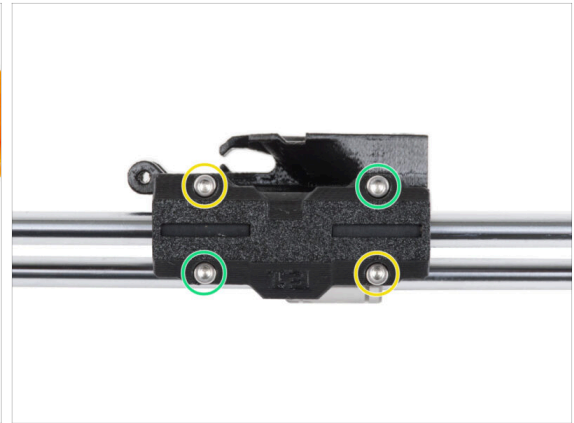
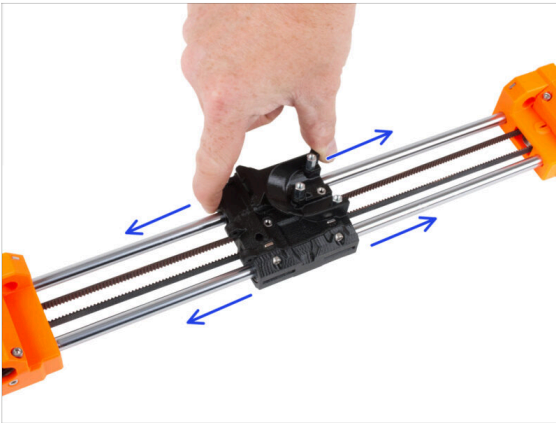

- ◆ Move with the X-carriage side to side several times to check that the movement is smooth.
- ◆ After you ensure that the movement is smooth, fully tighten the screws on the X-carriage-clip in this order:
 - ◆ Upper left screw
 - ◆ Lower right screw
 - ◆ Upper right screw
 - ◆ Lower left screw
- ◆ Move the X-carriage several to both sides and check the movement is still smooth.

STEP 38 Haribo



- ◆ Eat five gummy bears.
- ⓘ **Did you know that** the original gummy bears were inspired by the dancing bears of Europe, and Riegel named them "Gummibärchen," which means "little rubber bears" in German.

STEP 39 It's done!



- ◆ Compare your assembly with the picture.
- ◆ Everything is OK? **Nice job**, you just successfully assembled the X-axis assembly.
- ◆ Let's go the next chapter: **4. Z-axis assembly**

4. Z-axis assembly

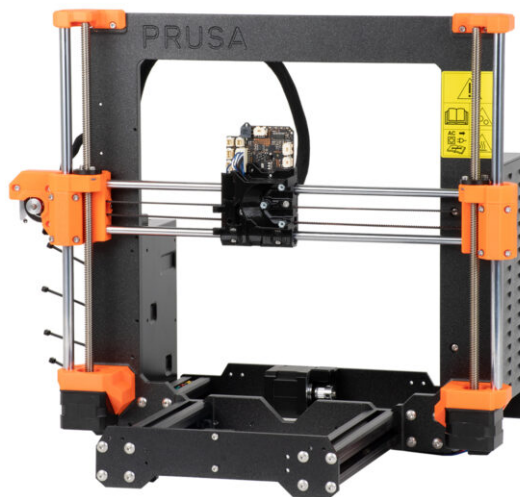

STEP 1 Tools necessary for this chapter

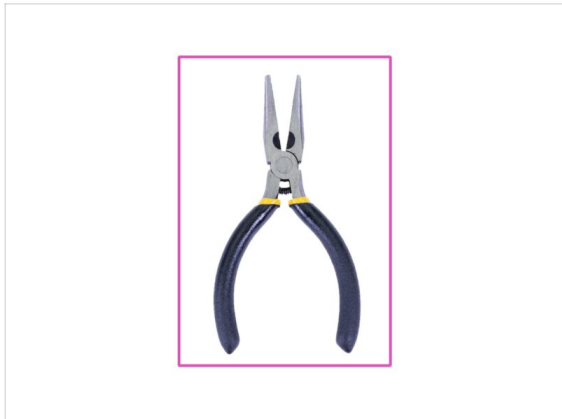
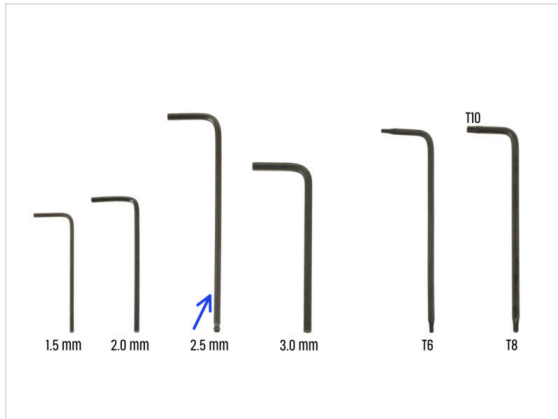

● For this chapter, please prepare:

- 2.5mm Allen key
- Needle-nose pliers

STEP 2 Assembling the Z-bottoms: parts preparation

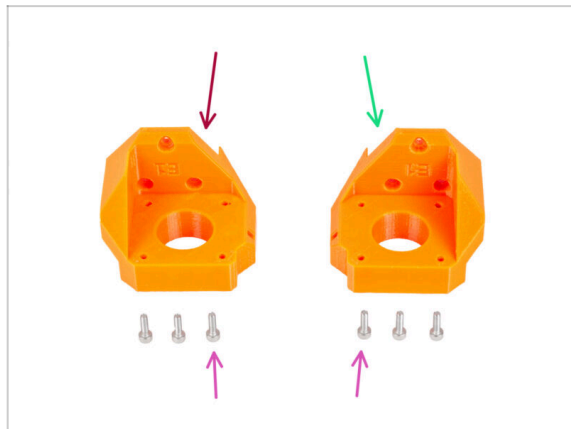

● For the following steps, please prepare:

- Z-bottom left (1x)
- Z-bottom right (1x)
- M3x10 screw (6x)

STEP 3 Assembling the Z-bottoms

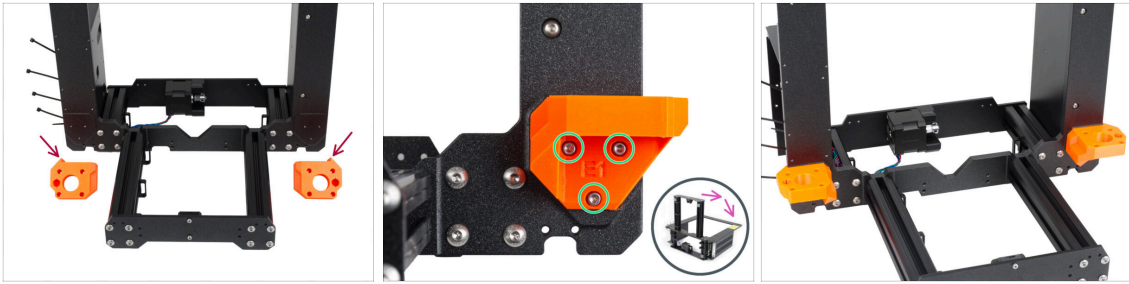

- ⚠ WARNING:** Printed parts aren't the same! There are left and right pieces. See the protrusion (tooth) on each part. For the right side of the frame, there is a protrusion on the right side of the plastic part and vice versa.
- 🟢 Attach both Z-bottoms to the frame and secure each part with three M3x10 screws.
 - 🟣 Tip: you can turn the printer on its back side for better access to the Z-bottom installation. It is recommended to place a cardboard pad under the printer to protect your workbench and the printer against scratches.
 - 📄 In case of increased resistance during tightening, try to run the screws through the threaded hole first without the printed part. Then remove the screws and attach the printed part.

STEP 4 Z motor assembling: parts preparation

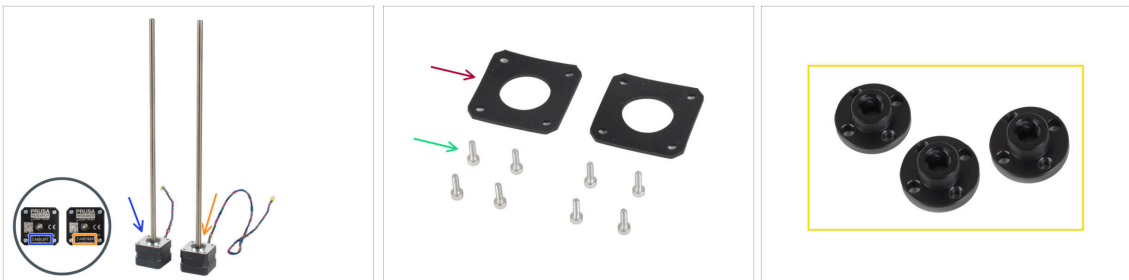

- 🛠 **For the following step, please prepare:**
- 🟡 Z motor left (labeled Z-axis left, shorter cable)
 - 🟠 Z motor right (labeled Z-axis right, longer cable)
 - 🟢 M3x10 screw (8x)
 - 🟤 Rubber pad 42x42x2 mm (2x)
 - 🟡 To avoid accidentally discarding parts, prepare the trapezoid nuts from the motor box and keep them in a safe place. You will need them in a few steps.

STEP 5 Attaching the rubber pads

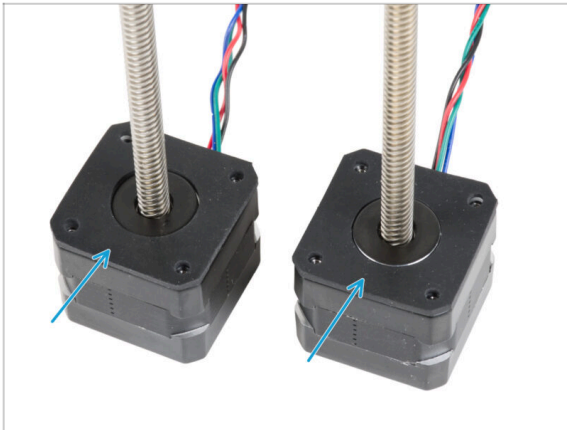

- Attach both rubber pads onto the motor surface. **Make sure the holes in the pads are aligned with the holes in the motors.**

STEP 6 Installing the Z motors

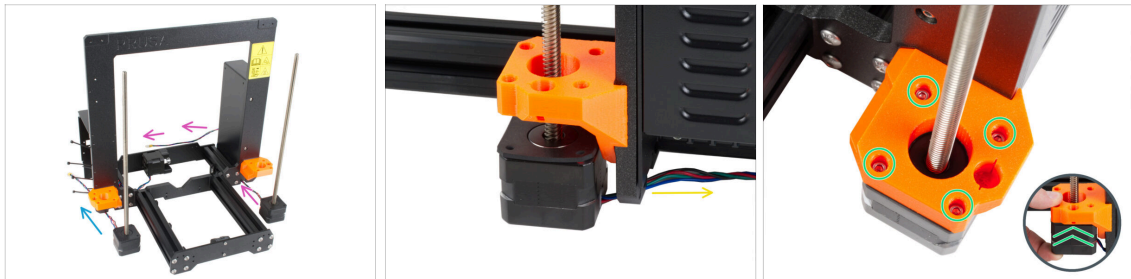

- Place the Z motor left (short cable) next to the left Z-bottom.
- Place the Z motor right (long cable) next to the right Z-bottom.
- The motor cables must guide under the frame to the PSU (right) and xBuddy Box (left).
- Push each motor through the Z-bottom and secure it with four M3x10 screws. **Do not tighten them completely at the moment.**

STEP 7 Connecting the Z motors

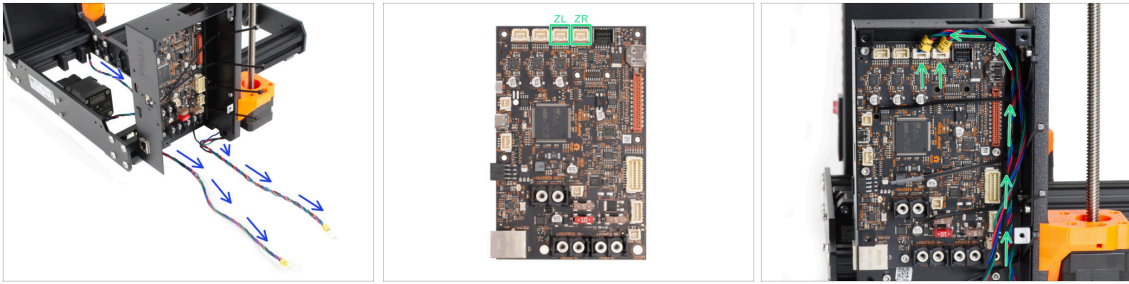

- ◆ Guide both the Z motor cables under the frame towards the xBuddy Box.
- ◆ Connect the cables to the third and fourth slots on top of the xBuddy Board. Motor cable labeled ZL connect into the left slot, ZR into the right.

STEP 8 Mounting the X-axis assembly: parts preparation

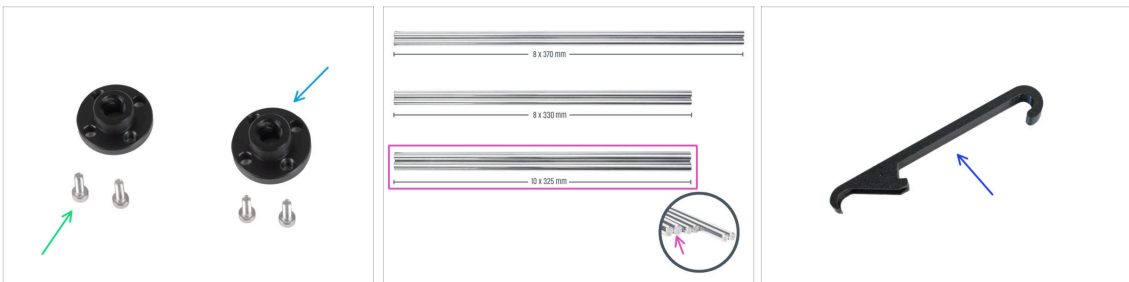

- ◆ **For the following steps, please prepare:**
- ◆ Trapezoidal nut (2x) *keep the remaining one as a spare*
- ◆ M3x10 screw (4x)
- ◆ Smooth rod 10 x 325 mm (2x)
- ◆ X-holder (1x)

STEP 9 Mounting the X-axis and smooth rods

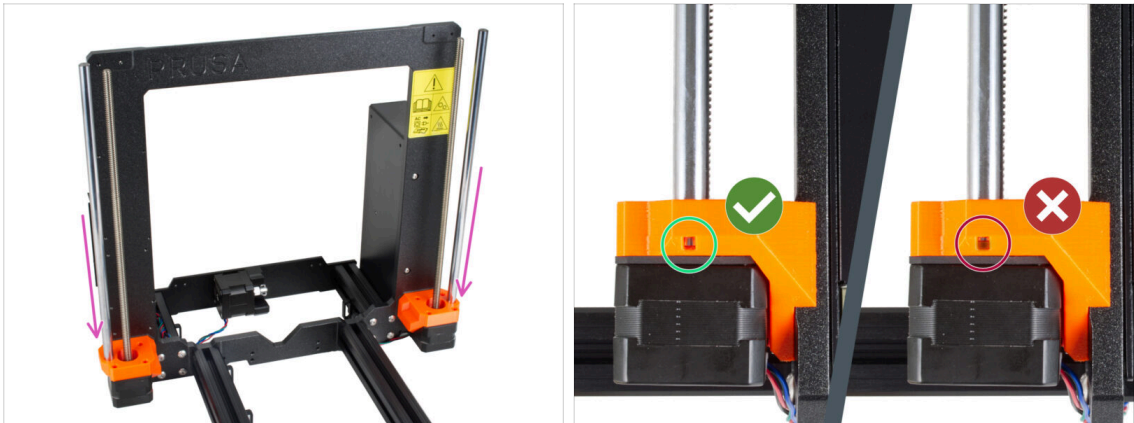

- ◆ Gently insert the smooth rods into Z-bottoms. **Do not apply too much force and do not tilt the rod!**
- ⓘ If the smooth rods are dirty or have too much preservative oil on them, wipe them with a paper towel.
- ⚠ Through the inspection hole in both Z-bottoms, check if the rod is completely inserted. **There must be no gap between the smooth rod and the bottom of the hole.**

STEP 10 Assembling the X-axis and smooth rods

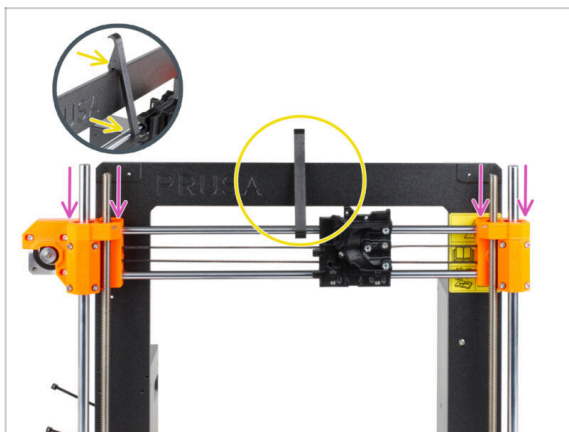

- ◆ Carefully slide the X-axis assembly onto the Z-axis smooth rods.
- ◆ **Secure the position of the X-axis to the frame.** Engage the X-holder **IN THE CENTER** of the X-axis by the top smooth rod and then by the printer frame.
- ⚠ It is important to place the X-holder at the center of the frame and the X-axis. If not, the centering results could be inaccurate.

STEP 11 Installing the X-axis assembly

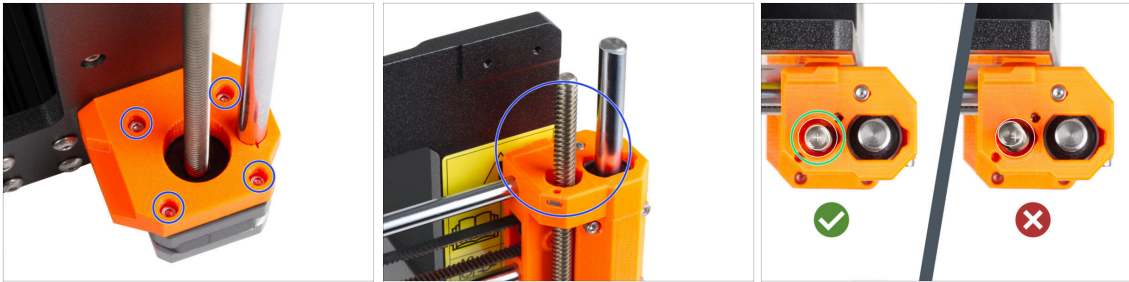

- i Centering the threaded rods of the Z motors is important. However, it doesn't have to be perfect. See the following instructions for more:
 - ◆ Start with the **right Z motor**.
 - ◆ By carefully and gradually tightening the individual screws holding the Z motor, align the threaded rod in the X-end-idler. **Watch the threaded rod move while tightening.** Tightening the right front screw tilts the top of the rod to the rear left - and vice versa. **Tighten all screws firmly.**
 - ⚠ Take a look at the threaded rod from the top. **The threaded rods should be close to the center of the X-end-idler hole as much as possible.** The threaded rod shouldn't touch the surface of the printed part. See the third picture.
 - ◆ **PROCEED THE SAME WITH THE LEFT Z MOTOR.**

STEP 12 Assembling the trapezoidal nuts

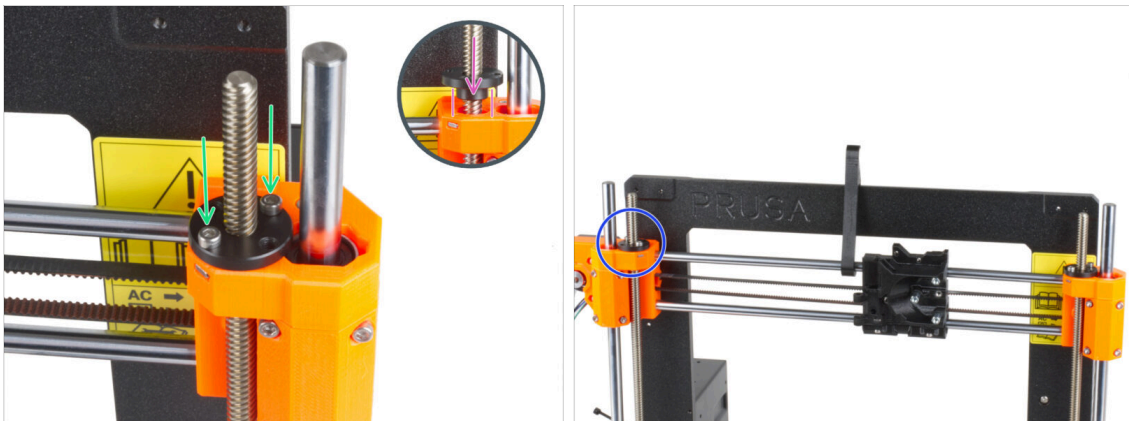

- ◆ Screw the trapezoidal nut onto the right threaded rod. **Note the correct orientation of the nut.** The smaller diameter of the nut must fit into the hole in the X-end. If it does not, the threaded rod is incorrectly centered.
- ◆ Secure the trapezoidal nut with two M3x10 screws. It does not matter which holes in the nut you use.
- i There may be a small gap between the trapezoidal nut and the printed part. Tightening the two screws will cling the nut completely to the part.
- ◆ In the same way, install the second trapezoidal nut on the X-end-motor (left threaded rod).

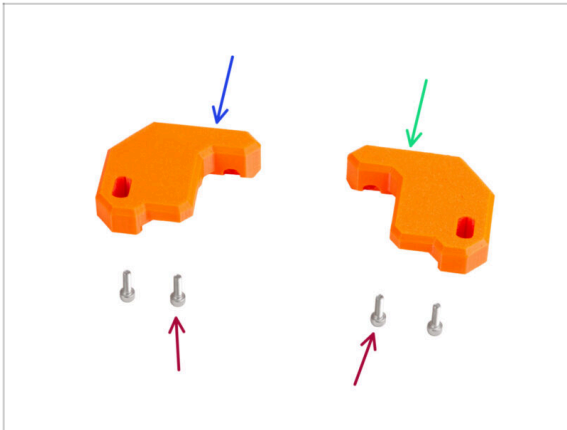
STEP 13 Installing the Z-top parts: parts preparation

◆ For the following steps, please prepare:

- ◆ Z-top-left (1x)
- ◆ Z-top-right (1x)
- ◆ M3x10 screw (4x)

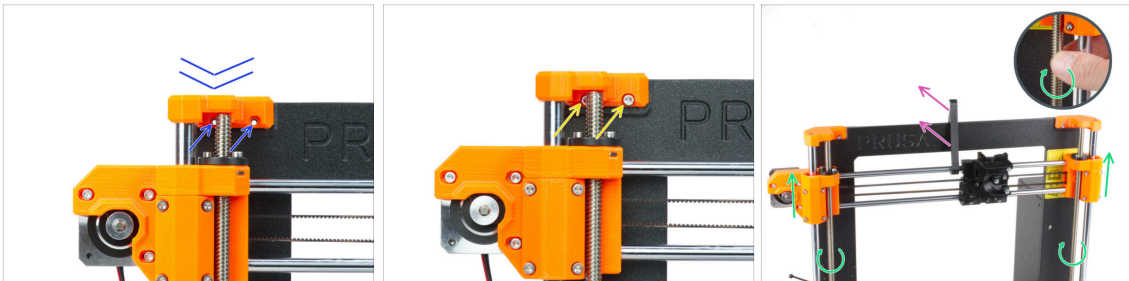
STEP 14 Placing the Z-top parts

- ◆ Place the Z-top-left on the rods and align it with the frame, and align the holes in the plastic parts with the holes in the frame.
- Use two M3x10 screws to attach the Z-top-left.
 - ⚠ **Don't use excessive force during tightening.** In case of increased resistance, try to run the screws in from the other side of the frame first to "clean up" the threaded hole. Then return to the front side.
 - ⓘ Tip: move the X-axis a few centimeters down for make some space if you can reach the screw behind the rod.
- ◆ Repeat this step on the other side of the frame with Z-top-right printed part.
- ◆ Rotate both threaded rods in parallel to move the X-axis assembly a few centimeters higher to release the X-holder.
- ◆ Remove the X-holder from the printer.

STEP 15 LoveBoard: parts preparation

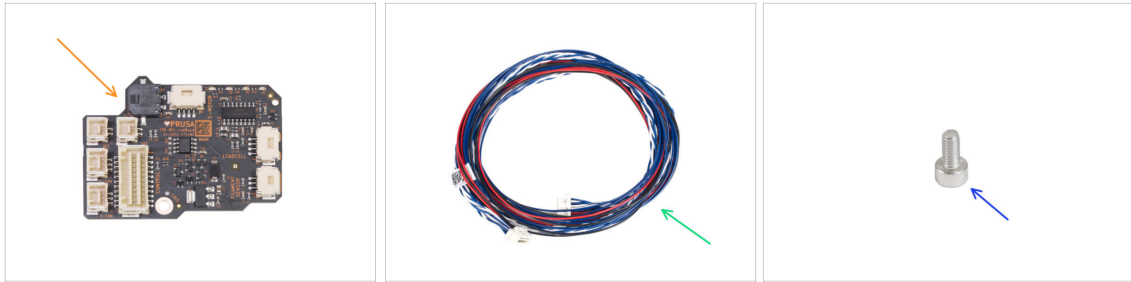

◆ For the following steps, please prepare:

- ◆ LoveBoard (1x) *included in the ELE package*
- ◆ Extruder main cable (1x)
- ◆ M3x6 screw (1x)

STEP 16 Assembling the LoveBoard

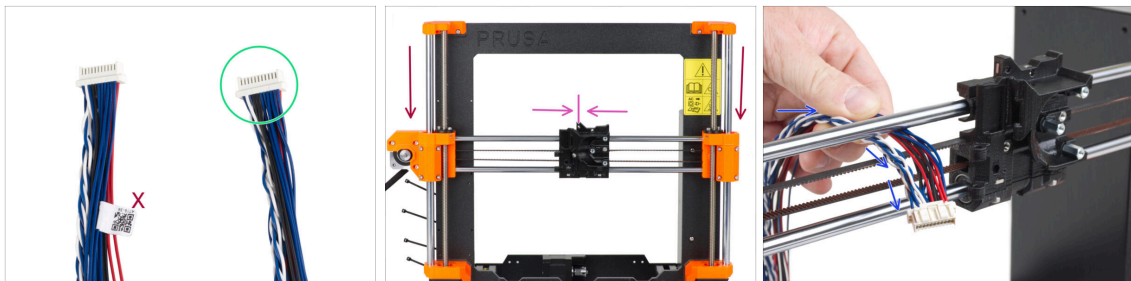

- ◆ Take the end of the extruder main cable without the white label.
- ◆ Move the X-axis assembly to the center of the Z-axis height.
- ◆ Move the X-carriage approximately to the center of the X-axis.
- ◆ From the back of the printer, guide the extruder main cable to the front of the printer through the gap between the belt and the upper rod.

STEP 17 Connecting the extruder main cable

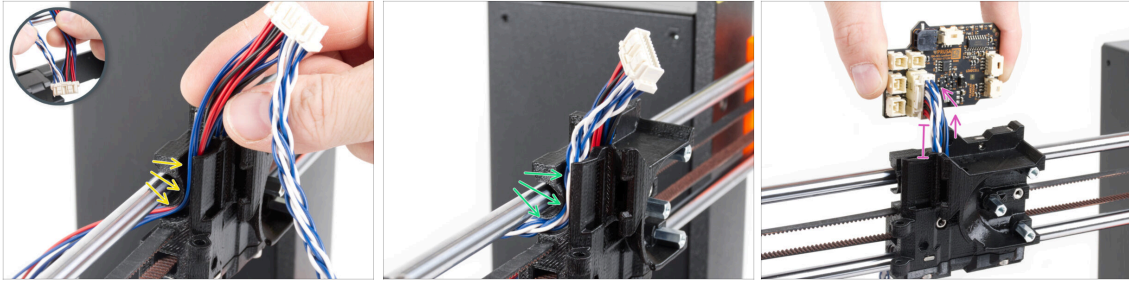

- ◆ Divide the twisted wires and straight cables from each other.
- ◆ **First, guide the straight cables** through the channel in the X-carriage.
- ◆ **Then guide the twisted cables** through the channel.
- ◆ Connect the extruder main cable to the LoveBoard. Leave the extruder main cable extended approximately 2 centimeters (0.8 inches).

STEP 18 Mounting the extruder main cable

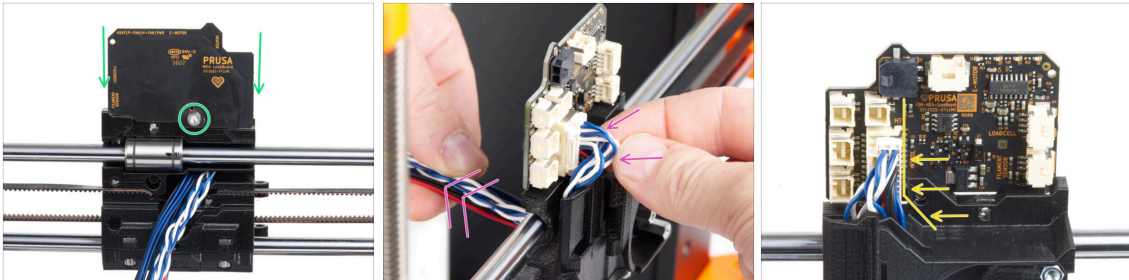

- ◆ Attach the LoveBoard to the back of the X-carriage and secure it with the M3x6 screw.
- ◆ Very gently pull on the extruder main cable bundle to reduce the bundle on the connector side. There must be a minimal loop. Otherwise, the cable will interfere with other parts in the next chapter.
- ◆ The cables must not interfere with the extruder motor compartment.

STEP 19 Connecting the extruder main cable: parts preparation



- For the following steps, please prepare:
- X-carriage-cable-holder (1x) with the screw hole
- M3x40 screw (1x)

STEP 20 Connecting the extruder main cable

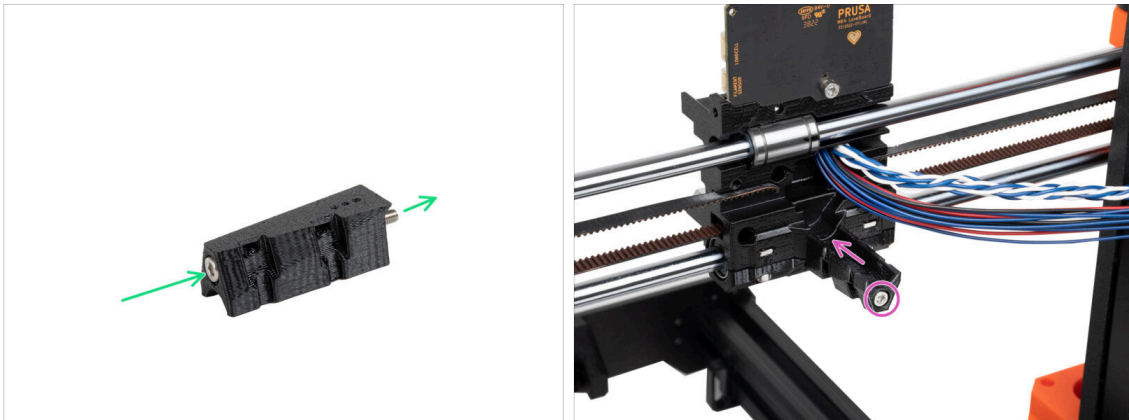

- Push the M3x40 screw through the X-carriage-cable-holder.
- Attach the X-carriage-cable-holder to the X-carriage underneath the extruder main cable and tighten the M3x40 screw.

⚠ **Do not pinch any wire of the extruder main cable!**

STEP 21 Covering the X-carriage: parts preparation

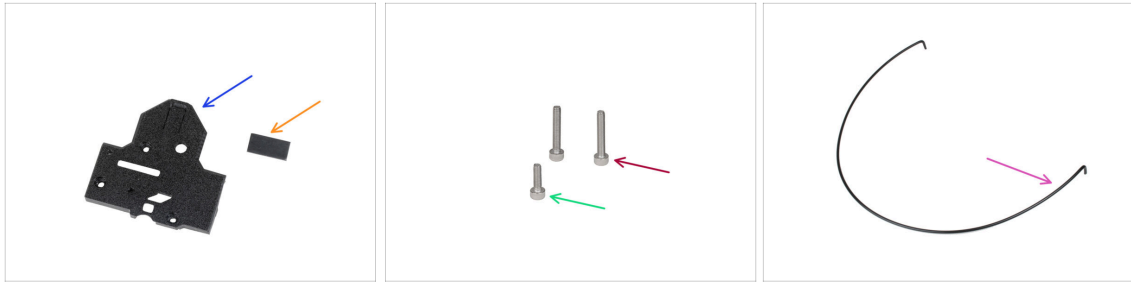

◆ For the following steps, please prepare:

- ◆ X-carriage-back (1x)
- ◆ Rubber pad 20x10x1 (1x)
- ◆ M3x18 screw (2x)
- ◆ M3x10 screw (1x)
- ◆ Nylon 3x555 mm (1x)

STEP 22 Covering the X-carriage: inserting the nylon filament

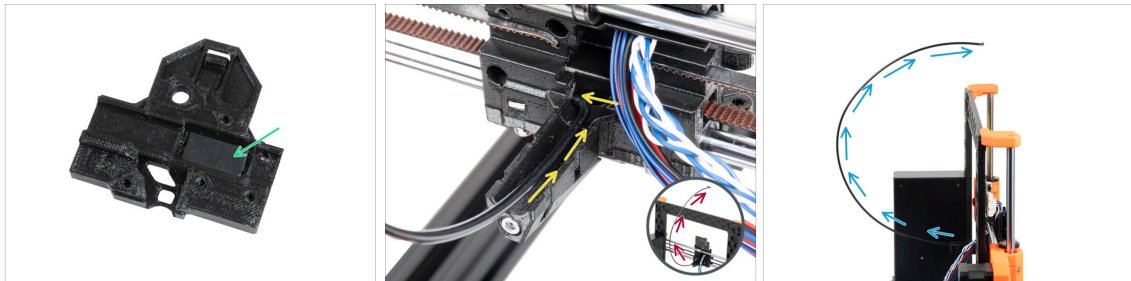

- ◆ Place the rubber pad into the rectangular pocket in the X-carriage-back.
 - ◆ Insert one of the bent ends of the nylon filament into the hole located on the left side of the extruder main cable channel in the X-carriage.
- ⚠ **The nylon filament must CURVE UPWARDS. Not down, not to sides. See the detail.**
- ◆ After the nylon filament holds in the X-carriage, check that it inclines upwards as seen in the picture. If it is pointing down instead, re-install the nylon filament into the X-carriage by the other bent end and check again.

STEP 23 Attaching the X-cover-back

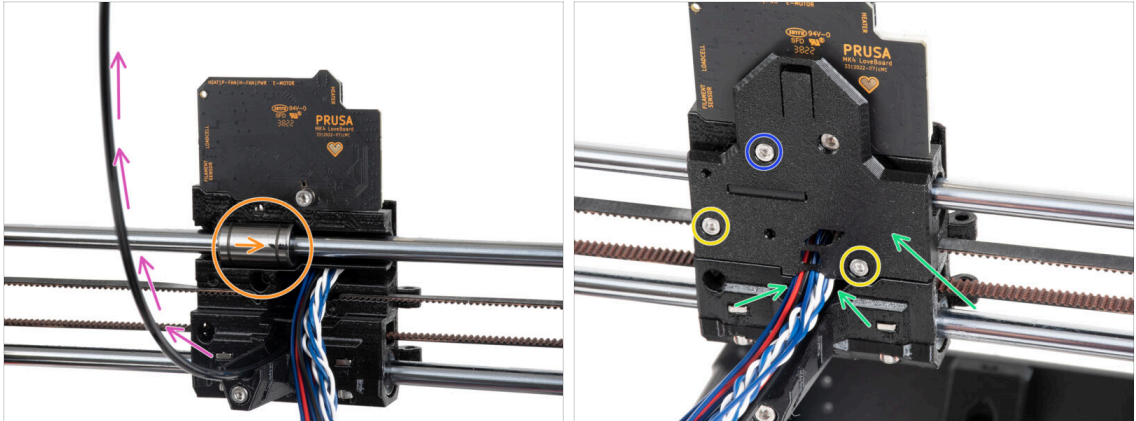

- ◆ **Before we cover the back of the X-carriage, make sure that:**
 - ◆ the upper bearing is in the pocket inside the X-carriage and the marking is facing you
 - ◆ the nylon filament is pointing upwards
 - ◆ Place the X-carriage-back on the X-carriage and arrange the main cable wires like in the picture.
- ⚠ **Be careful, no wire must be pinched!**
- ◆ Secure the X-carriage-back with two M3x18 screws.
- ◆ Insert and tighten the M3x10 screw into the upper hole in the X-carriage-back.

STEP 24 Guiding the main-cable: parts preparation

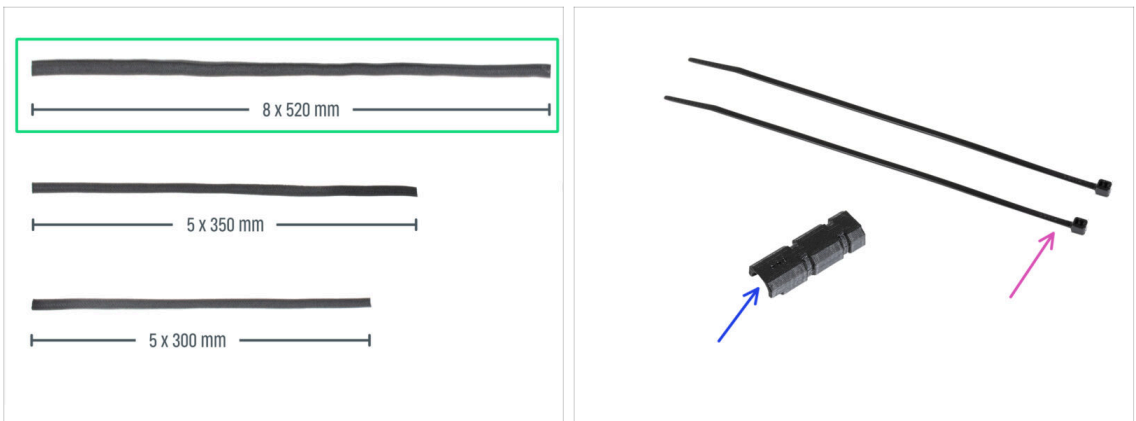

- ◆ **For the following steps, please prepare:**
 - ◆ Textile sleeve 8x520 (1x)
 - ⓘ There are three different textile sleeve sizes in your kit package. You can always make sure by comparing their lengths.
 - ◆ Zip tie (2x)
 - ◆ X-carriage-cable-holder-cover (1x)

STEP 25 Wrapping the extruder main cable

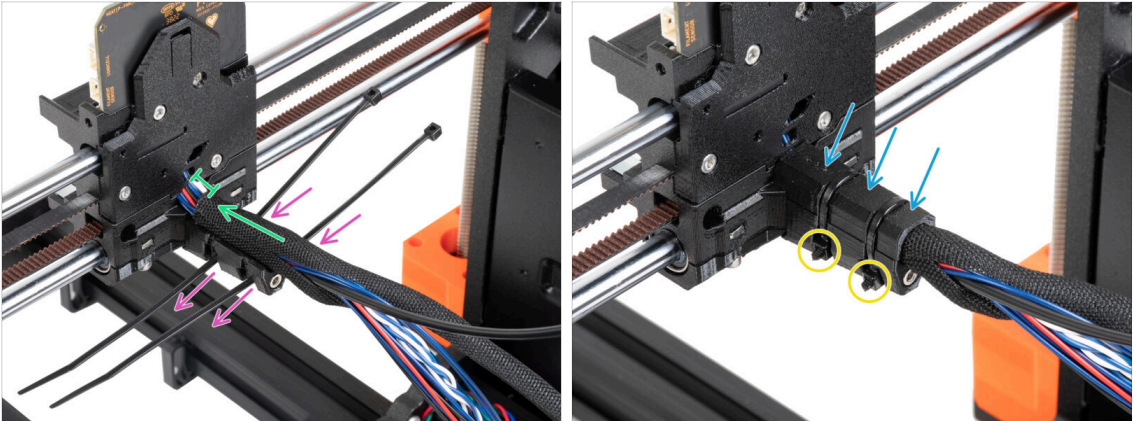

- ◆ Push two zip ties through the X-carriage-cable-holder. See the correct orientation of the zip ties.
- ◆ Wrap the extruder main cable and the nylon filament near the X-carriage with the textile sleeve. Keep a 1 cm (0.39 inches) gap between the sleeve and the X-carriage. Wrap just this part near the joint, for now, we will continue wrapping the bundle in the next step.
- ◆ Cover it with X-carriage-cable-holder-cover.
- ◆ Tighten both zip ties so that the "heads" fit into the pockets in the plastic part. Cut off the excess cable tie.

⚠ It is important that the heads of the zip ties are seated in the pockets. Otherwise, they may collide with the printer frame during X-axis calibration and the calibration could fail.

STEP 26 Wrapping the textile sleeve

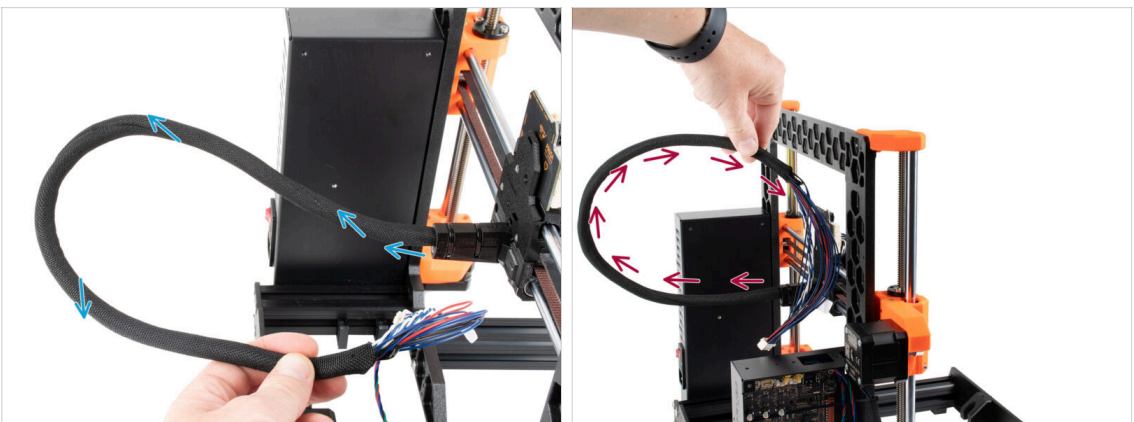

- ◆ Wrap the textile sleeve around the extruder main cable and nylon filament.
 - ◆ Proceed in a spiral motion around the bundle so that it is tightly bound together.
 - ◆ Hold the cable bundle upwards while wrapping and continue until it is fully wrapped.

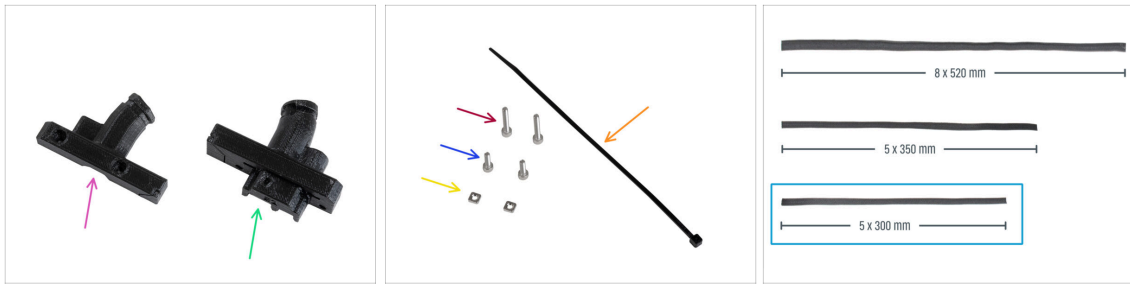
STEP 27 Attaching the Ext-cable-holder: parts preparation

◆ **For the following steps, please prepare:**

- ◆ Ext-cable-holder-b (1x)
- ◆ Ext-cable-holder-a (1x)
- ◆ Zip-tie (1x)
- ◆ M3x18 screw (2x)
- ◆ M3x10 screw (2x)
- ◆ M3nS nut (2x)
- ◆ Textile sleeve 5x300 mm (1x)

STEP 28 Wrapping the X motor cable

- ◆ Wrap the X motor cable to the textile sleeve.
- ⓘ It's alright that the textile sleeve doesn't go over the full length of the motor cable.

STEP 29 Attaching the Ext-cable-holder

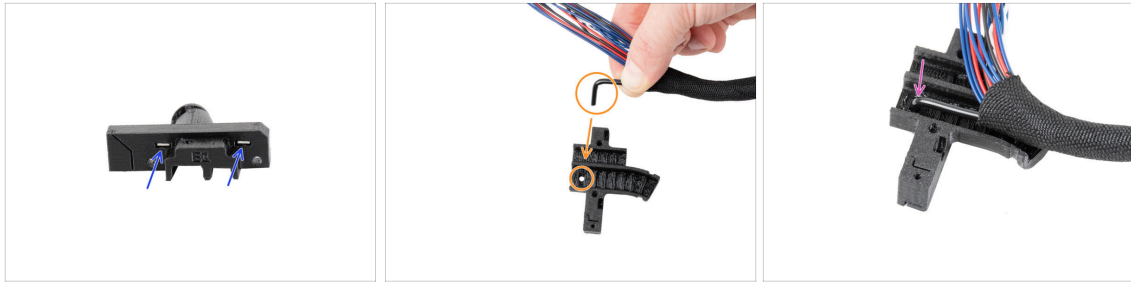

- ◆ Insert two M3nS nuts all the way into the Ext-cable-holder-a.
- ◆ Take the bent end of the nylon filament. And locate the hole in the Ext-cable-holder-a.
- ◆ Push the bent part of the nylon filament into the hole in the Ext-cable-holder-a.

STEP 30 Assembling the Ext-cable-holder



- ◆ Guide the extruder main cable freely from the printer. Do not twist or rotate it.
 - ◆ Guide the X motor cable freely from the printer.
 - ◆ Insert the extruder main cable in the cable channel in the Extr-cable-holder-a.
 - ◆ Take the X motor cable and guide it **over the extruder main cable** through the left channel in the Ext-cable-holder-a.
- ⚠ Guiding the X motor cable behind the main cable could cause problems with axis travel when printing.

STEP 31 Assembling the Ext-cable-holder



- ◆ Cover the cables with the Ext-cable-holder-b and secure it with two M3x18 screws.
- ◆ Secure the Ext-cable-holder together with the zip tie in the groove. Tighten up the zip tie and cut off the excess of the zip tie.

STEP 32 Assembling the Ext-cable-holder

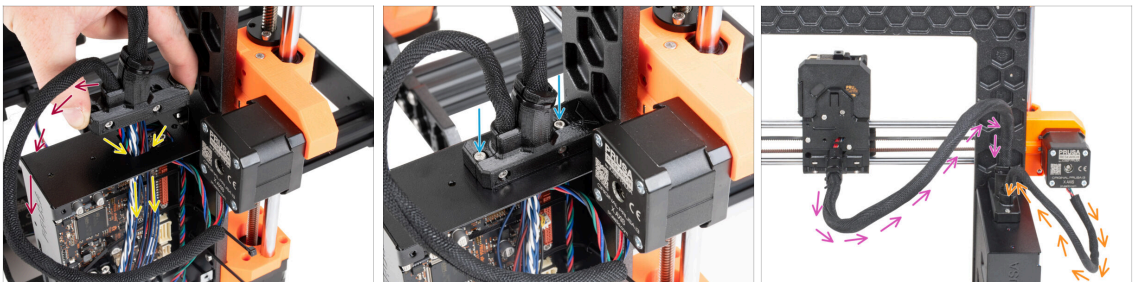

- ◆ Push the X-axis motor cable and the extruder main cable through the hole in the xBuddy Box to the electronics.
- ⚠ Double-check that the **X motor cable does not guide behind the extruder main cable**. Compare it according to the picture.
- ◆ Attach the Ext-cable-holder onto the xBuddy box with the two M3x10 screws.
- ◆ Leave the cables free in the xBuddy box for now. We will connect them later on.
- ◆ According to the third picture, compare the guiding of the extruder main cable. Note the curve of the cable guide.
- ◆ Compare the guiding of the X motor cable.

STEP 33 Reward yourself!

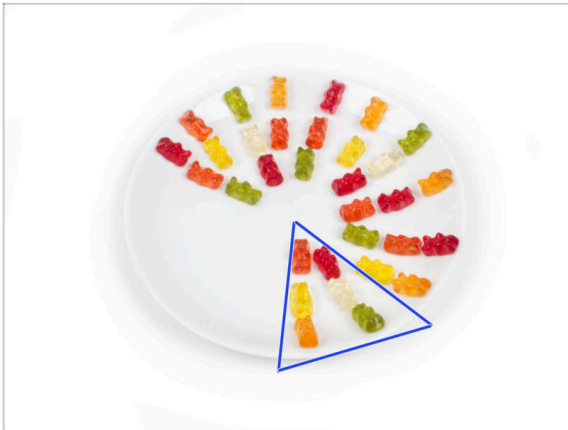

◆ Eat six gummy bears.

ⓘ **Did you know that** in 2014, a gummy bear-inspired emoji was added to the Unicode Standard, allowing gummy bear enthusiasts to express their love for the candy in digital conversations.

STEP 34 Here it is!

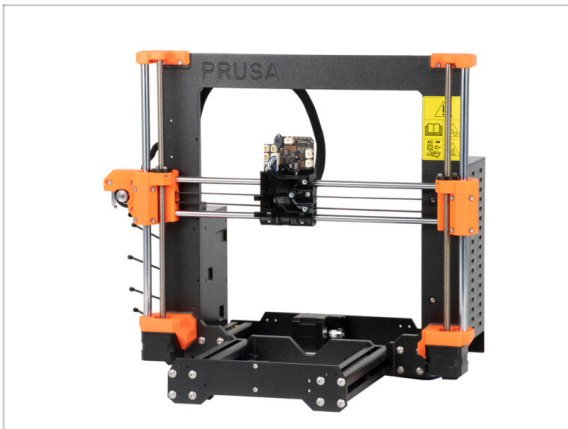

- ◆ Compare you build with the picture.
- ◆ Everything is right? Congratulations! You have successfully assembled the Z-axis with some other small things.
- ◆ So, let's continue with the next chapter: **5. Nextruder assembly**

5. Nextruder assembly

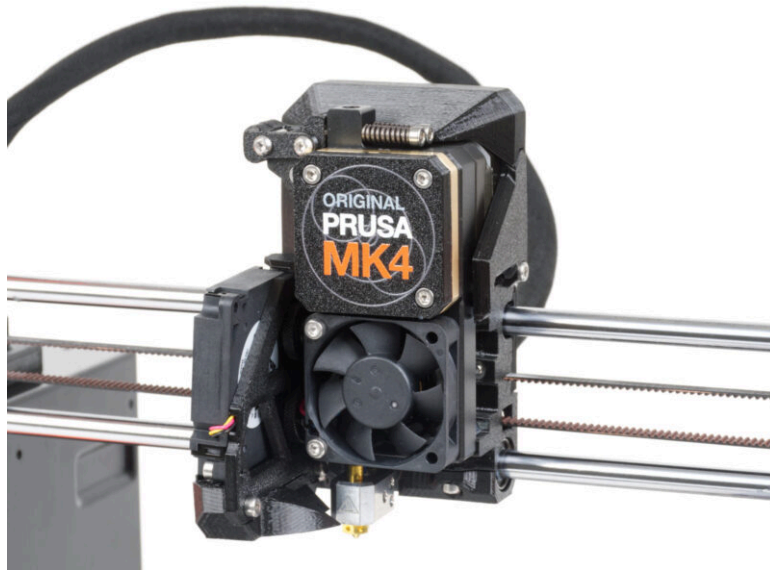

STEP 1 Tools necessary for this chapter

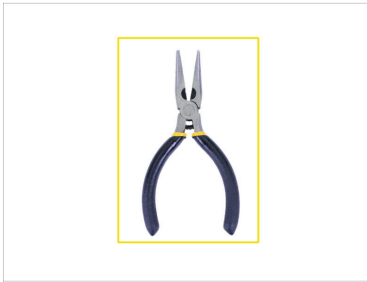
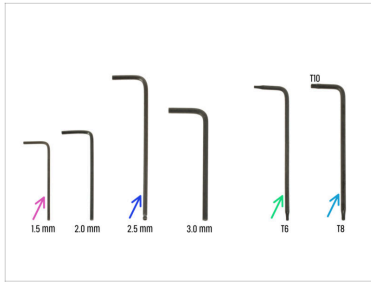

● **For this chapter, please prepare:**

- 1.5mm Allen key
- 2.5mm Allen key
- Torx key TX6
- Torx key TX10/8
- Needle-nose pliers
- Permanent marker

STEP 2 Filament sensor: parts preparation

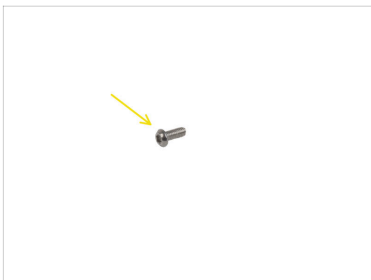
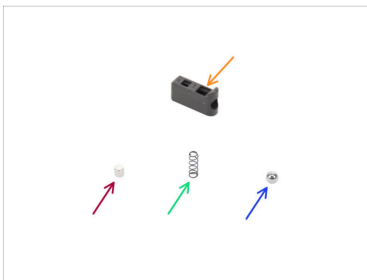

● **For the following steps, please prepare:**

- Nextruder heatsink (1x)
- Hall filament sensor (1x)
- Prusa ball holder (1x)
- Magnet 3x3x3 mm (1x)
- Spring 3x9 mm (1x) *smaller one*
- Steel ball 4 mm (1x)
- M2.5x6rT screw (1x)

STEP 3 Assembling the filament sensor



- ◆ Place the Hall filament sensor into the similarly shaped pocket in the heatsink.
- ◆ Fix it with M2.5x6rT screw. Tighten it very carefully, you can crack the electronics board.
- ◆ Assemble the Prusa ball holder in the following order:
 - ◆ Steel ball
 - ◆ Magnet
 - ◆ Spring
- ◆ Insert these parts into the Prusa ball holder with the steel ball up.

STEP 4 Assembling the filament sensor

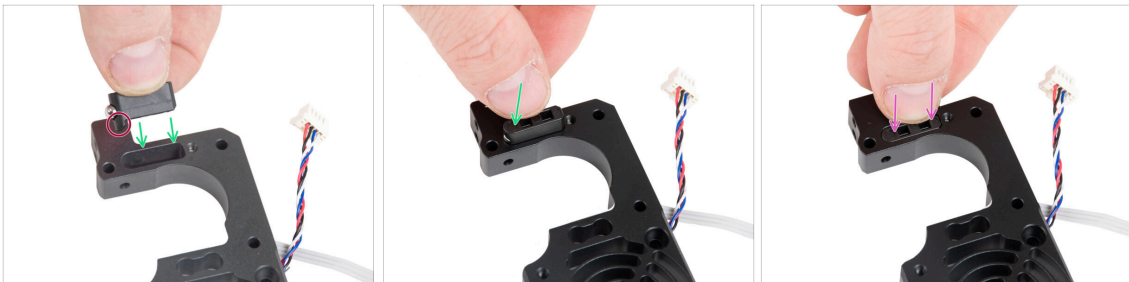

- ◆ Insert the Prusa ball holder assembly into the heatsink. Make sure the steel ball part is closer to the side of the heatsink.
 - ⚠ Note the **correct orientation of the Prusa ball holder assembly**. There is a protrusion on the part. The protrusion must be facing down.
- ◆ Push the assembly into the heatsink.

STEP 5 Nextruder idler assembly: parts preparation

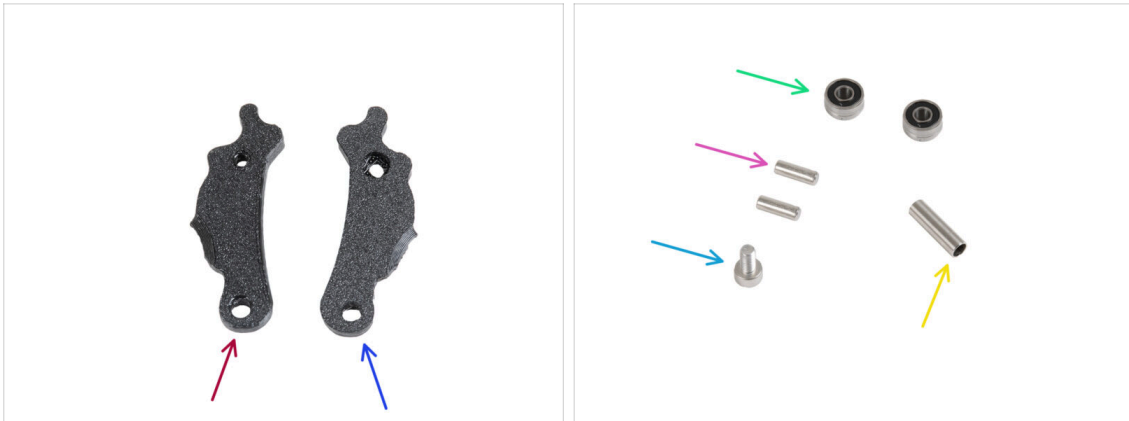

For the following steps, please prepare:

- Idler-lever-b (1x)
- Idler-lever-a (1x)
- Bearing 693 2RS (2x)
- Pin 2.9x8.5 (2x)
- M3x6 screw (1x)
- Tubular spacer 13.2x3.8x0.35 (1x)

STEP 6 Assembling the extruder idler



- Insert the pin 2.9x8.5 into each bearing 693 2RS, as seen in the picture.
- Place both bearings with the pins into the Idler-lever-b.
- Close it up with the Idler-lever-a part and secure it with the M3x6 screw. **Do not overtighten the screw.** Both bearings must be able to rotate without significant resistance.
- From the same side, push the tubular spacer into the assembly. The "bottom" of the tubular spacer must be flushed with the bottom part of the Idler assembly.

STEP 7 Assembling the extruder: parts preparation I.



◆ For the following steps, please prepare:

◆ PG-case (1x) *you will use it later*

◆ Main-plate (1x)

◆ PG-assembly-adaptor (1x)

◆ PG-assembly (1x)

◆ PG-ring (1x)

ⓘ The list continues in the next step...

STEP 8 Assembling the extruder: parts preparation II.

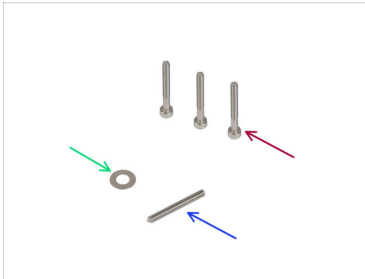
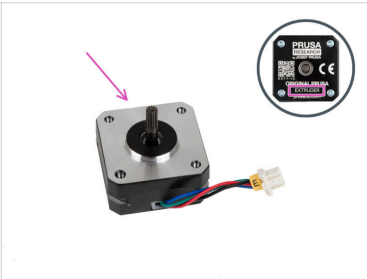

◆ Extruder motor (1x)

◆ M3x25 screw (3x)

◆ Spacer 5x10x0.1 mm (1x)

◆ Socket set screw M3x25 (1x)

◆ Lubricant (1x)

STEP 9 Assembling the extruder

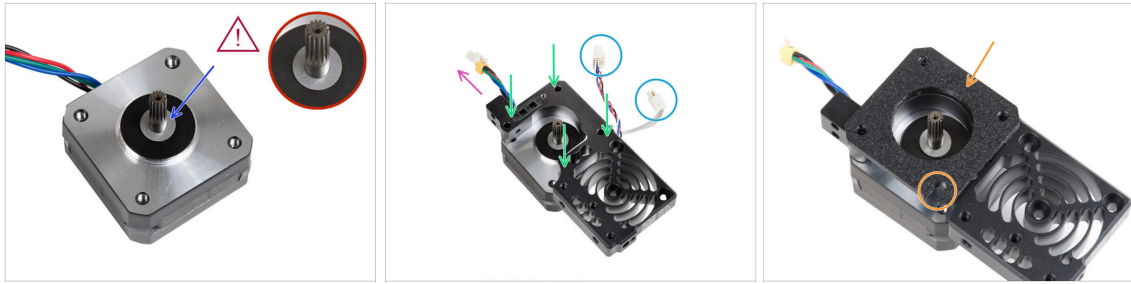

- ◆ Attach the 5x10x0.1 spacer over the shaft on the extruder motor.
- ◆ Place the heatsink on the extruder motor. Note the orientation of both parts.
 - ◆ The motor cable must be facing "up".
 - ◆ The heatsink cables must be on the right side.
- ◆ Attach the main-plate on the heatsink. Note the orientation of the part. Use the cutout as a guide.

⚠ Before proceeding to the next step, make sure that the 5x10x0.1 spacer is placed on the extruder motor.

STEP 10 Assembling the gearbox

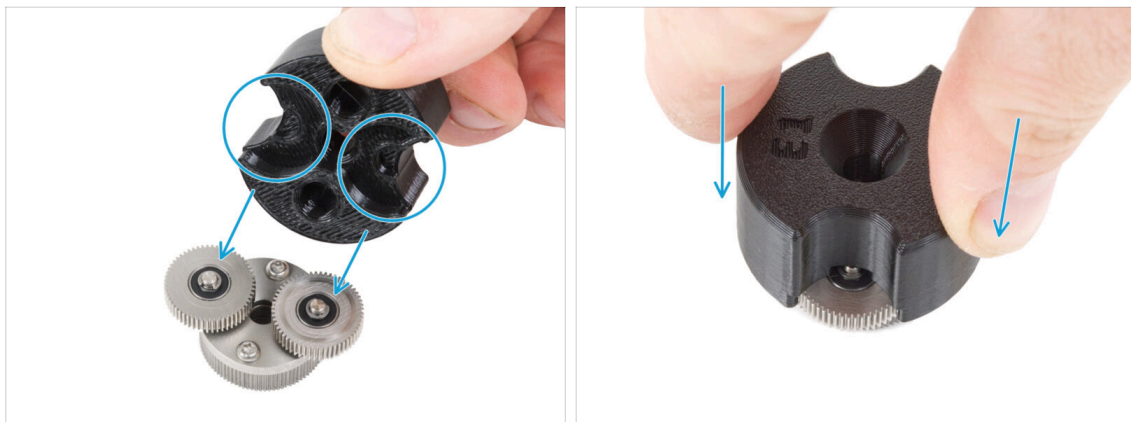

ⓘ **The following instructions need to be done correctly and carefully.** Achieve better understanding and successful assembly by watching the video alongside the guide: prusa.io/PG-assembly

- ◆ After watching the video, follow the steps in this guide.
- ◆ Attach the PG-assembly-adaptor on the PG-assembly. Note the pockets for the gears in the adaptor.

STEP 11 Assembling the PG-ring

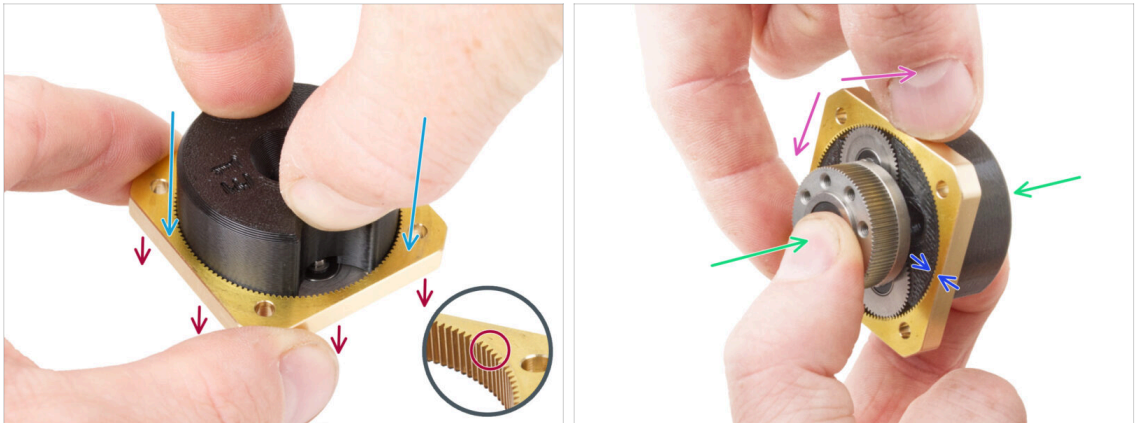

⚠ Do not assemble the gearbox without the PG-assembly-adaptor. This tool is intended to ensure that the gears are correctly fit together.

- Slide the PG-ring onto the adapter.
- Note there is a chamfer on one side of the PG-ring teeth. This side must be facing down (to the PG-assembly).
- Grasp the entire assembly in one hand so that it can be rotated with the PG-ring.
- With the other hand, slide the PG-ring onto the PG assembly in a wobbling motion (move the PG-ring left and right repeatedly) - a quarter turn is enough.
- Stop when the gear surfaces are flush with the PG-ring surface

STEP 12 Assembling the PG-assembly

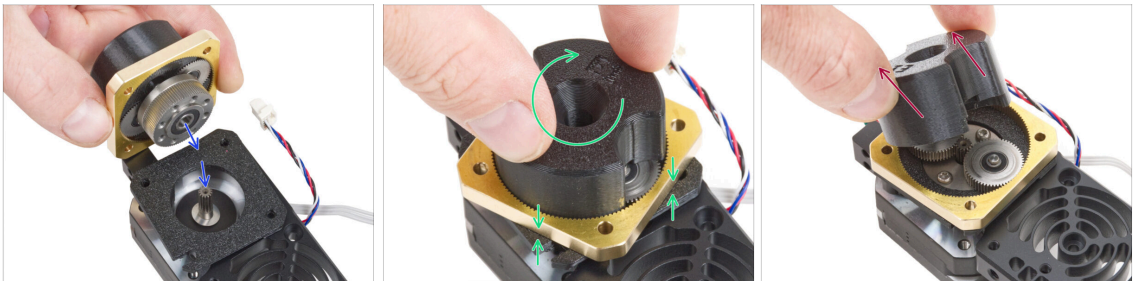

⚠ Proceed very carefully in this step.

- Maintain the position of the PG-assembly and attach it on to extruder motor shaft.
- Very gently and freely rotate with the whole PG assembly (PG-assembly-adaptor, PG-assembly and PG-ring) until it drops down so that there is no gap between the assembly and the main-plate. **Do not push on the assembly.**
- Remove the PG-assembly-adaptor.

STEP 13 Checking the PG-assembly

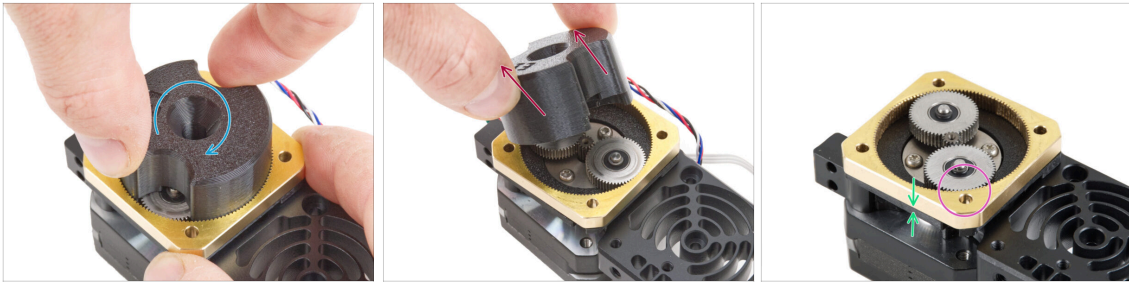

- Attach the PG-assembly-adaptor back on the PG-assembly again to verify that all parts are properly seated.
- Rotate with the PG-assembly-adaptor. **The movement of the PG assembly must be smooth and there should be no resistance.**
- Remove the PG-adaptor. You will no longer need it during assembly. We recommend keeping it for maintenance.
- Make sure both PG-ring and PG-assembly are sitting flush.
- There must be no gap between PG-ring and the Main-plate. If you see a gap, remove the planetary gear assembly and reposition it again.

STEP 14 Assembling the Nextruder idler

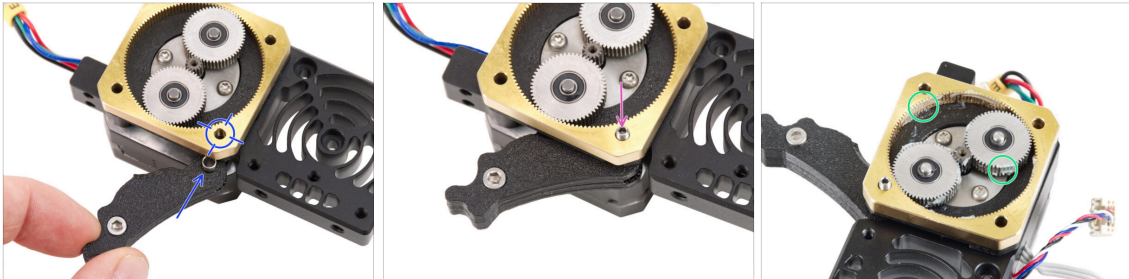

- Insert the idler assembly between the PG-ring and the extruder motor. There is a cutout for the spacer in the main-plate. Line up the idler spacer with the hole in the PG-ring.
- Secure both parts with the socket set screw 3x25. **Do not overtighten the screw! The screw protrudes from the PG-ring after tightening.**
- Apply a small amount of Prusa Lubricant all around the PG-ring and PG-assembly teeth.
- ⓘ Tip: apply a small amount of lubricant to the tip of the zip tie and then spread the lubricant over the gears.
- Using a paper towel, wipe off any excess lubricant on the front surfaces.

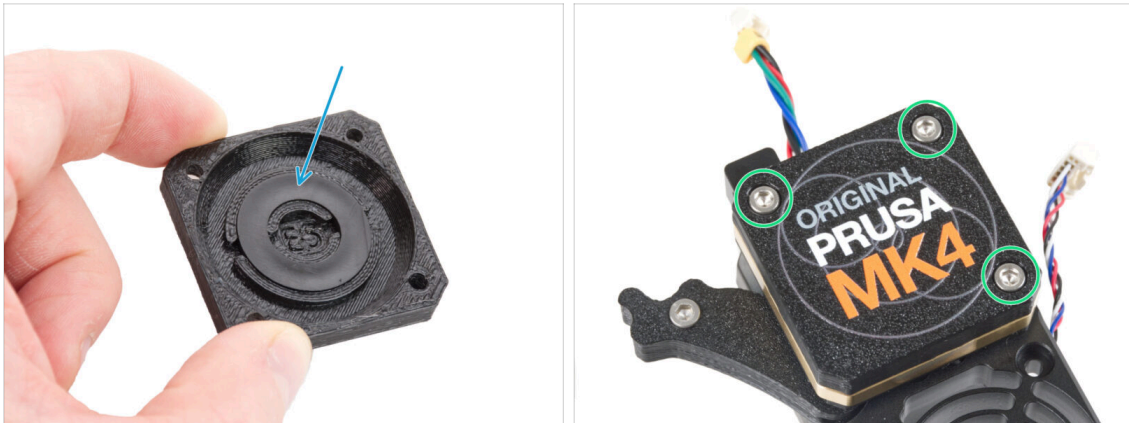
STEP 15 Covering the planetary gear

- Take the PG-cover and **make sure the plastic ring is already inserted** in the part.
- ⓘ If the plastic ring is not part of cover, you can finish the assembly, but before you start printing get in touch with the Prusa support. This part ensures smooth movement of the planetary gear.
- The color of the plastic ring might vary. The properties are the same.
- Cover the planetary gear and secure the PG-case with three M3x25 screws. **Do not overtighten the screws!**

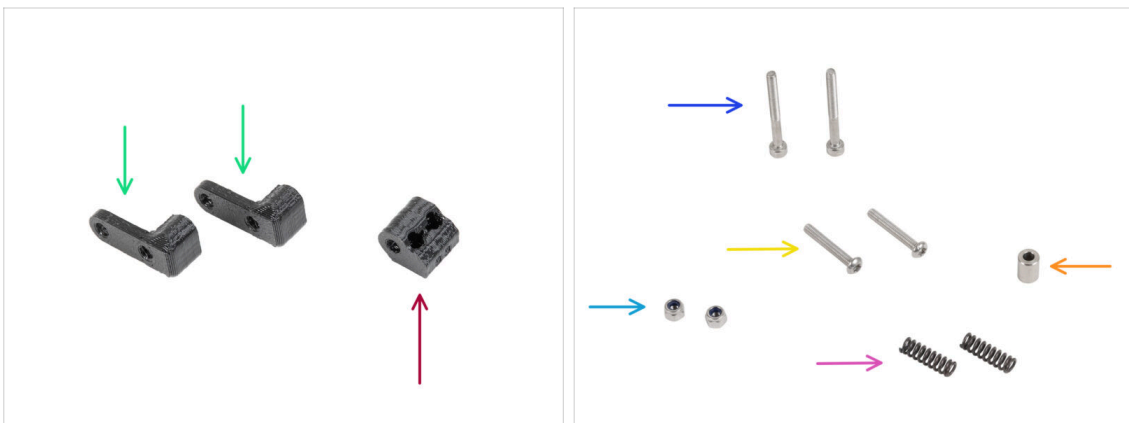
STEP 16 Assembling the Idler-swivel: parts preparation

- **For the following steps, please prepare:**
- Idler-nut (1x)
- Idler-swivel (2x)
- M3x30 screw (2x)
- M3x20rT screw (2x)
- M3nN nut (2x)
- Spring 15x5 (2x)
- Spacer 5.5 mm (1x)

STEP 17 Assembling the Idler-swivel

- ◆ Push the M3x20rT screw all the way through one of the idler-swivel.
- ◆ Slide the spacer onto the screw.
- ◆ Place the second idler-swivel from the opposite side on the screw.
- ◆ From the other side, attach the M3nN nut onto the screw. Hold the nut using the universal wrench and tighten the screw. **Tighten just lightly!** The spacer must rotate freely.

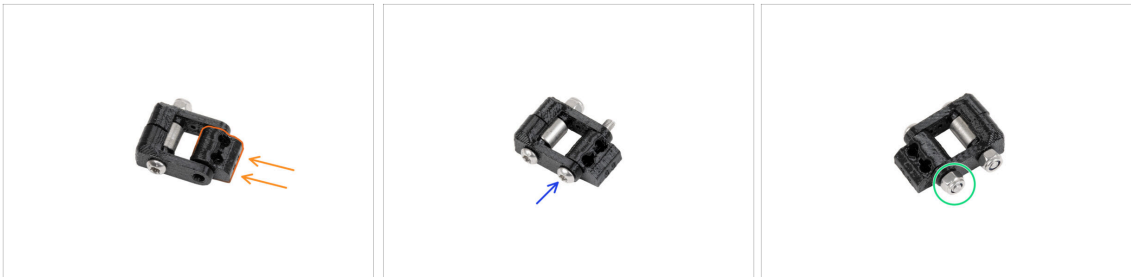
STEP 18 Assembling the Idler-nut

- ◆ Insert the Idler-nut into the Idler-swivel assembly. Make sure that both parts are oriented correctly according to the picture.
- ◆ Secure both parts together by inserting the M3x20rT screw from the same side, like the first screw.
- ◆ Secure the screw with M3nN nut. **Do not overtighten the nut.** It must be possible to move with the Idler-swivel on the Idler-nut.

STEP 19 Mounting the Idler-swivel assembly

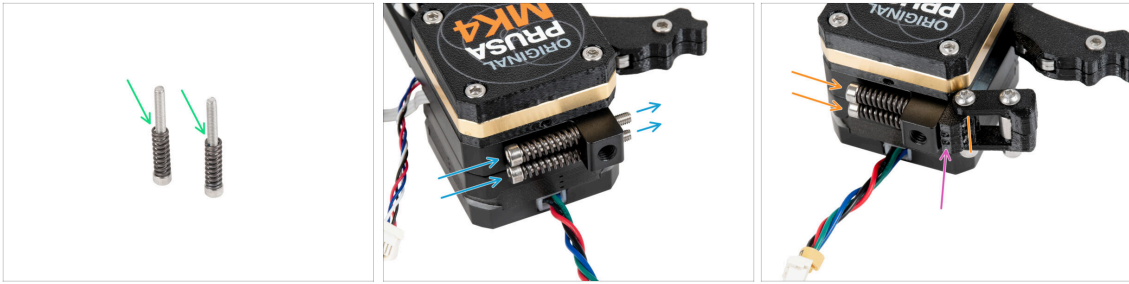

- ◆ Attach the spring 15x5 on both M3x30 screws.
- ◆ Push the two screws with the springs through the holes in the protrusion on the heatsink. There are no threads inside.
- ◆ Attach the Idler-swivel assembly on the screws. See the correct orientation of the Idler-nut. The side with two dots must be visible. See the picture.
- ◆ Tighten both screws. **Stop tightening as soon as the screw tips reach the front face of the idler nut.**

STEP 20 Attaching the extruder: parts preparation

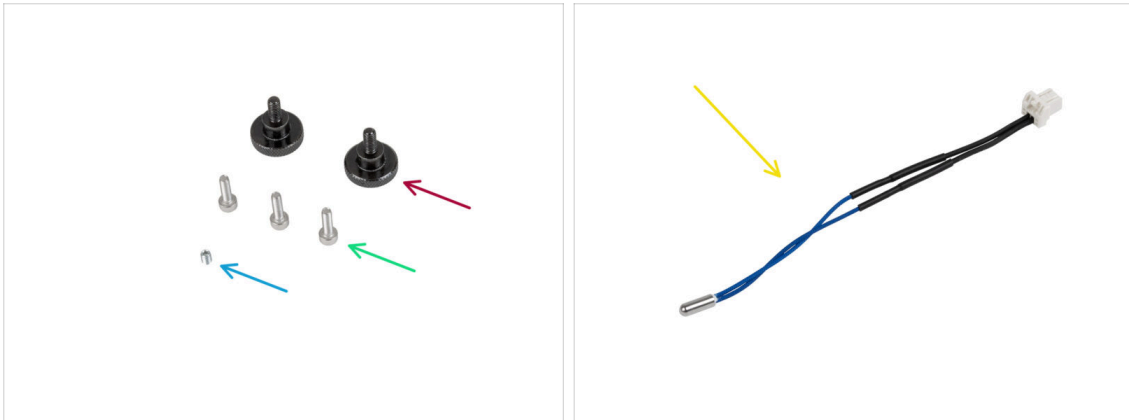

- ◆ **For the following steps, please prepare:**
- ◆ Thumb screw (2x)
- ◆ M3x10 screw (3x)
- ◆ M3x4T grub screw (1x)
- ◆ NTC thermistor 90 mm (1x)

STEP 21 Assembling the heatsink

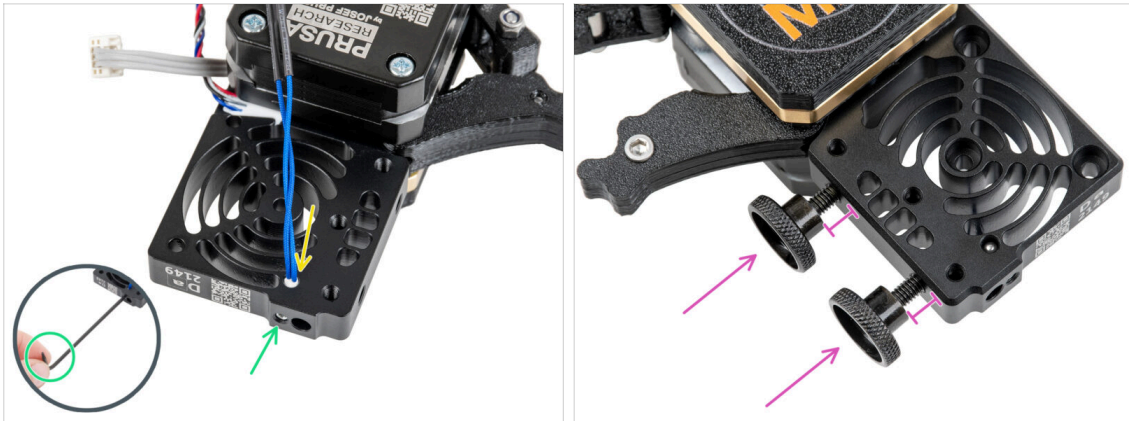

- On the extruder motor side, insert the NTC thermistor into the hole in the heatsink.
- Secure it with the M3x4T grub screw. Screw it all the way in. **Tighten gently, but firmly** using two fingers and the short side of the T6 Torx key. Applying more force may cause permanent damage to the thread.
- Insert two thumb screws into the heatsink. Do not tighten them completely. Two turns are enough for now.

STEP 22 Attaching the extruder

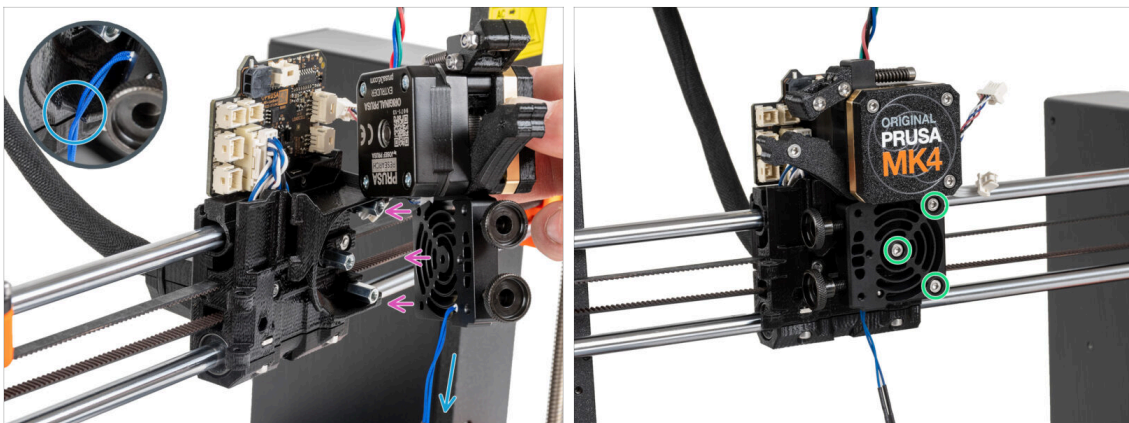

- Place the Nextruder onto the spacers on the X-carriage.
- There is a cutout in the plastic part. Guide the thermistor cable through this cutout.
 - ⚠ **DO NOT PINCH ANY OF THE CABLES!**
- Align the heatsink holes with the spacers on the X-carriage and join both parts together with three M3x10 screws. Start with the middle one.

STEP 23 Connecting the NTC thermistor



- ◆ Locate the cable channel on the left side of the X-carriage. We will guide some of the cables through this channel in the following steps
- ◆ Guide the NTC thermistor through the cable channel in the X-carriage up to the LoveBoard connector.

STEP 24 Assembling the hotend fan: parts preparation

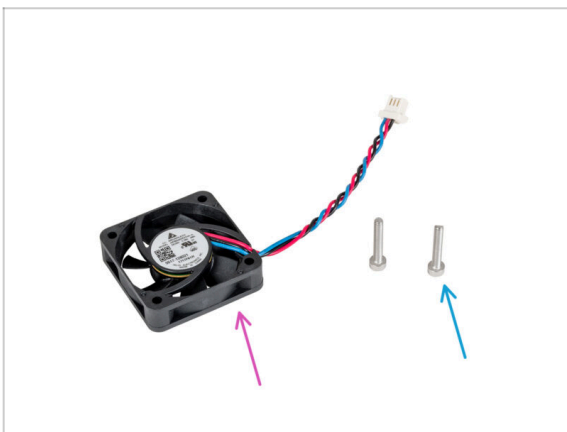

- ◆ For the following steps, please prepare:
- ◆ Hotend fan (1x)
- ◆ M3x18 screw (2x)

STEP 25 Assembling the hotend fan

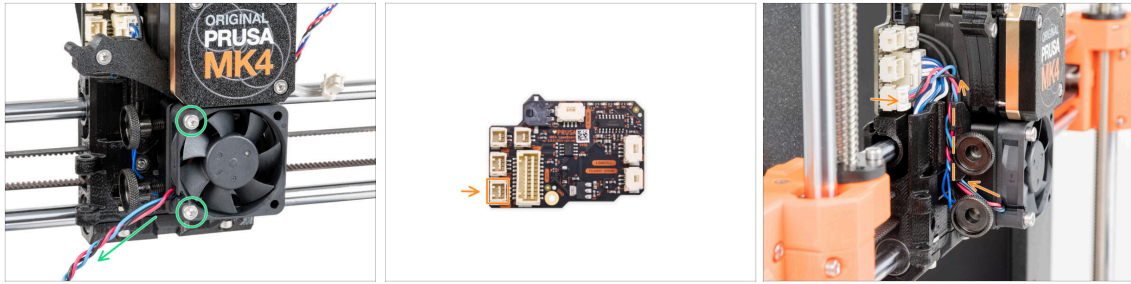

- Attach the hotend fan onto the heatsink with two M3x18 screws on the left side. **Tighten the screw gently, but firmly**, otherwise the plastic housing may crack. The **cable must be pointing towards the lower-left corner**.
- ⚠ There is a sticker on the hotend fan, the sticker must be on the rear side of the fan - not visible.
- Guide the fan cable between the thumb screws under the cable channel up and connect it to the **lower slot** on the LoveBoard.

STEP 26 Inserting the hotend assembly: parts preparation

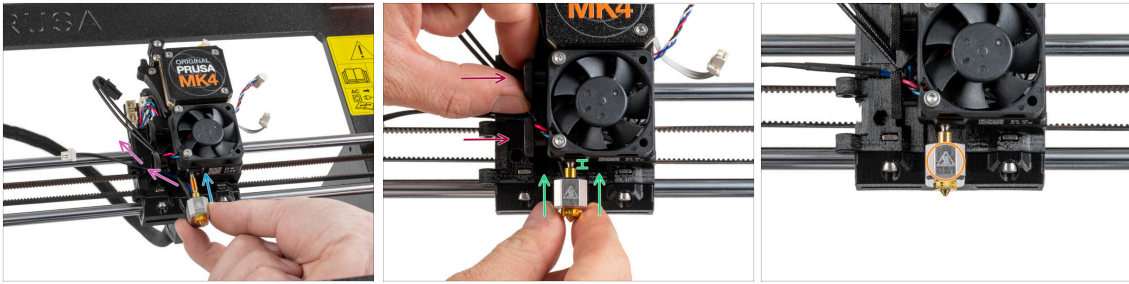

- For the following steps, please prepare:
- Hotend assembly (1x)

STEP 27 Inserting the hotend assembly

- ◆ Locate the hole in the heatsink from the bottom of the extruder and insert the hotend into the heatsink.
- ◆ Guide the hotend cables freely to the left.
- ◆ Push the hotend assembly all the way into the heatsink. There should be approximately a 2 mm gap between the heatsink and the brass part of the nozzle.
- ◆ While pushing the hotend assembly in, **firmly tighten both thumb screws**.
- ⚠ **Avoid pinching any cable between the screws and the heatsink!**
- ◆ Orient the hotend assembly so that the HOT symbol on the heaterblock faces forward.

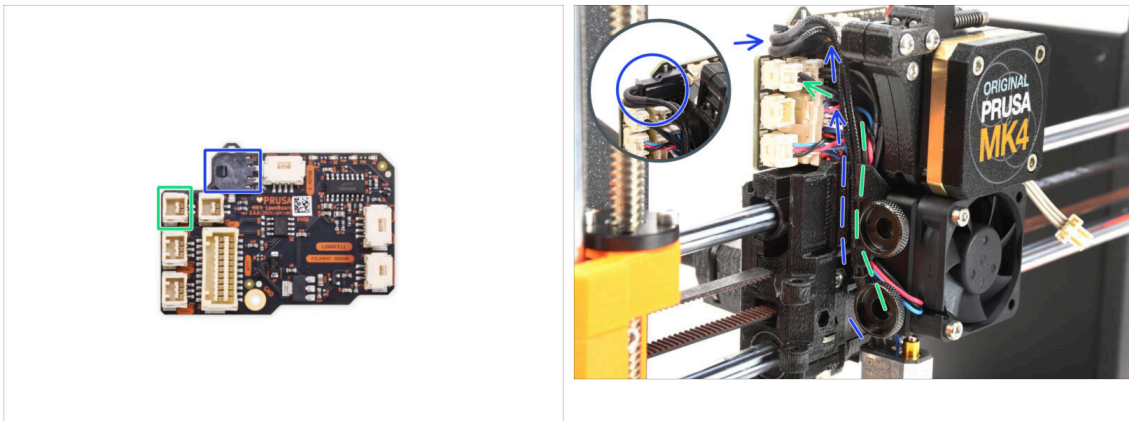
STEP 28 Connecting the hotend cables

- ◆ Guide the hotend thermistor through the cable channel in the X-carriage and connect it to the LoveBoard.
- ◆ Guide the hotend heater through the cable channel in the X-carriage and connect it to the LoveBoard.

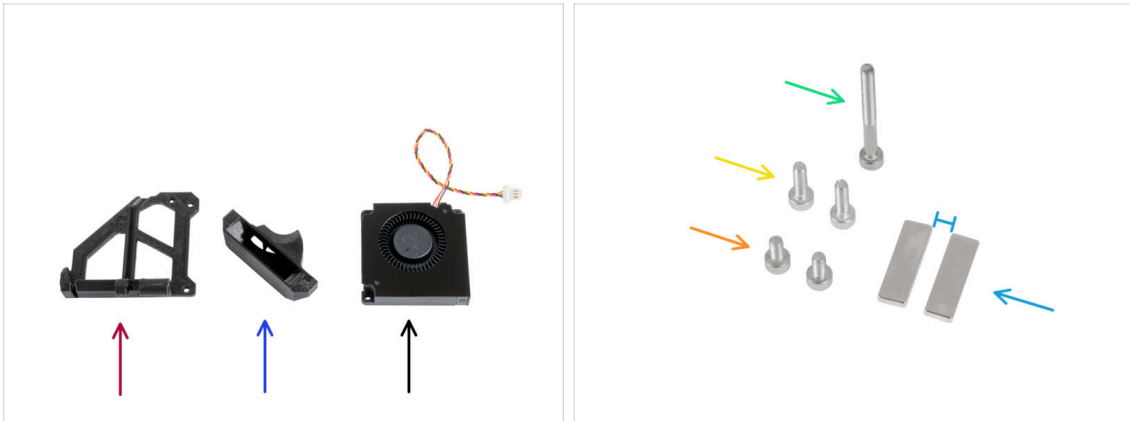
STEP 29 Assembling the fan-door: parts preparation

● For the following steps, please prepare:

- Fan-door (1x)
- Fan-shroud (1x)
- Print fan (1x)
- M3x30 screw (1x)
- M3x10 screw (2x)
- M3x6 screw (2x)
- Magnet 20x6x2 (2x) **Keep the magnets apart in a sufficient distance. They can break each other!**

STEP 30 Assembling the fan door

- Insert the magnet into the pocket on the inside of the fan-door.
- Arrange the print fan as seen in the picture. Guide the cable through the channel in the plastic part. Keep a small gap between both parts.
- Turn (close) the fan around and attach it to the fan-door by using two M3x6 screws.
- Pull the fan cable **very gently** to reduce the slack as much as possible.

STEP 31 Assembling the fan-door

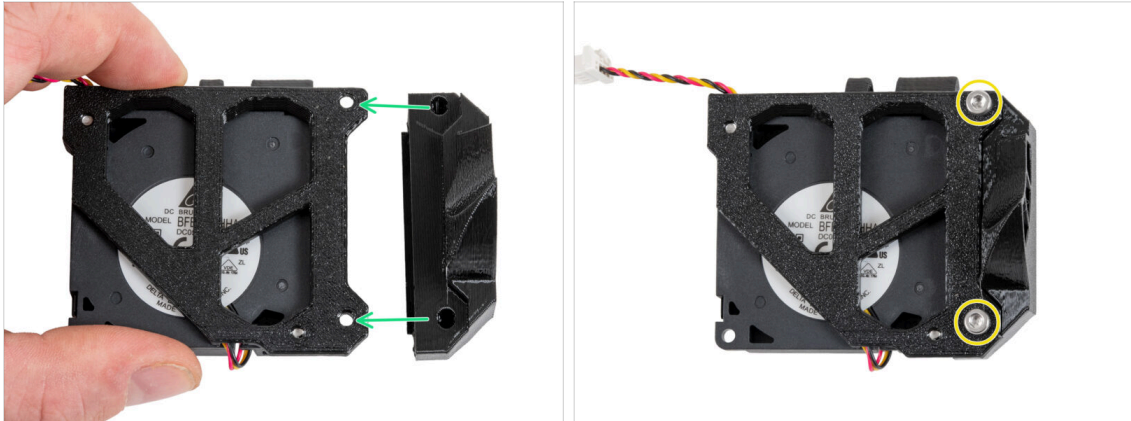

- ◆ Turn the fan-door assembly as shown.
- ◆ Attach the fan-shroud to the fan-door and align the holes in both parts.
- ◆ Join both parts together with two M3x10 screws.

STEP 32 Assembling the fan-door

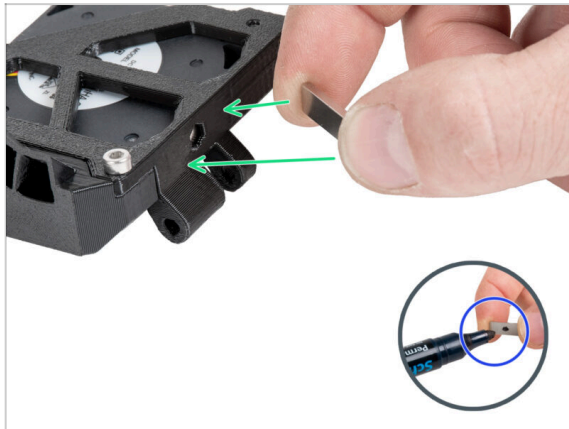

- ⓘ It is recommended to prepare the permanent marker for this step or have a very good eidetic memory ;).
- ◆ Slowly get the free magnet close to the magnet in the fan-door and find out which two sides are attracted to each other.
- ⚠ **Be careful that the magnets do not stick together, it will be difficult to separate them.**
- ◆ Mark the sides that are attracted to each other with a permanent marker.

STEP 33 Assembling the fan-door

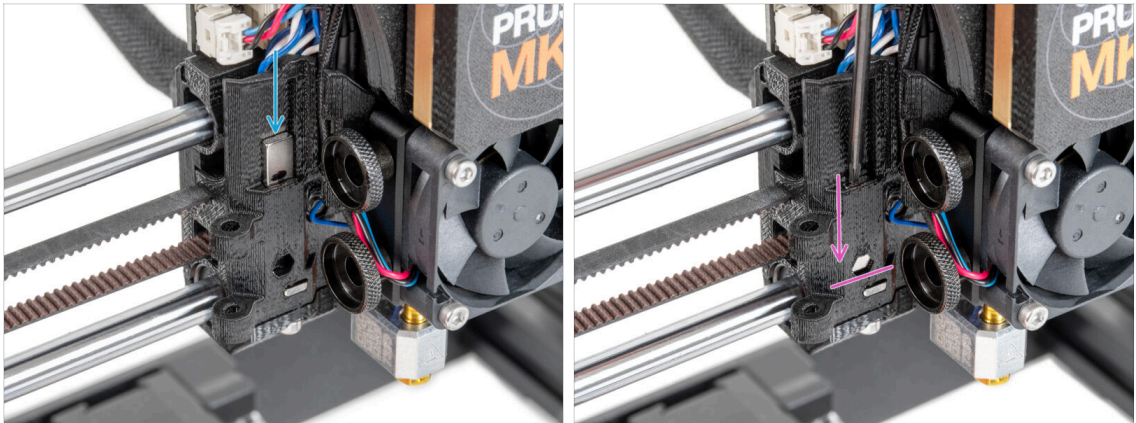

- Locate the hole for the magnet on the left side of the X-carriage.
- ⚠ Before inserting the magnet into the part, **double-check that the marked part of the magnet is FACING YOU**. The magnet cannot be removed from the part afterward.
- Insert the magnet into the hole so that the marked side is facing out of the X-carriage (to you).
- Push the magnet all the way down.

STEP 34 Assembling the fan-door

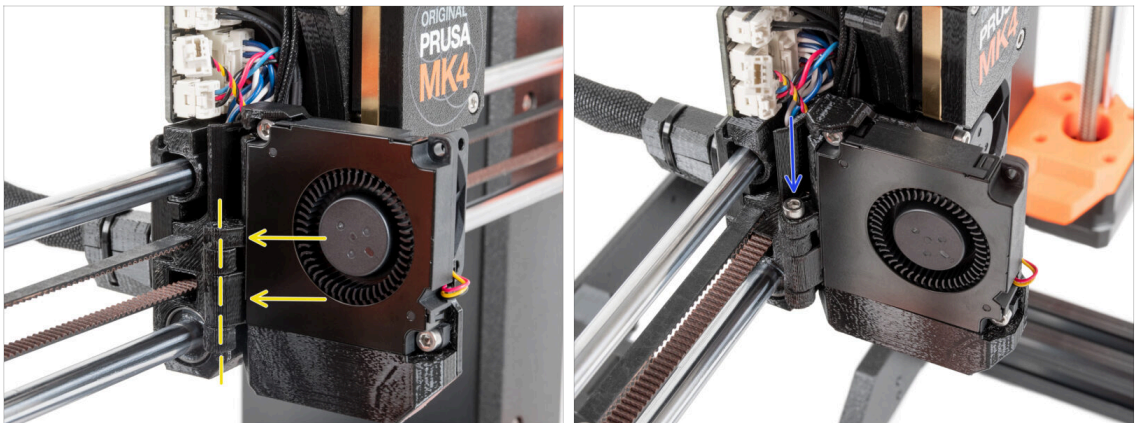

- Attach the fan-door hinge into its counterpart in the X-carriage. Holes in both parts must be aligned
- Insert the M3x30 screw in the hinge on the fan-door. Fully tighten the screw, then loosen it by a quarter turn. **The fan-door must move freely!**

STEP 35 Connecting the extruder cables

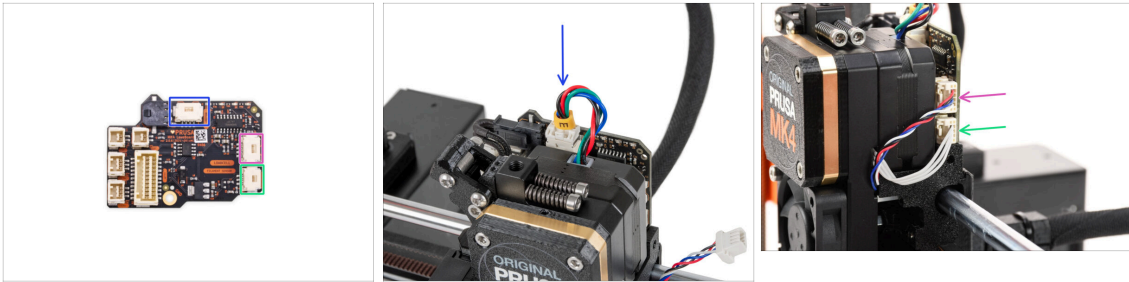

- ◆ Connect the Extruder motor cable to the connector on the top side of the LoveBoard.
- ◆ Connect the Loadcell cable coming from the right of the heatsink to the upper slot on the right side of the LoveBoard.
- ◆ Connect the filament sensor cable to the lower slot on the right side of the LoveBoard.

STEP 36 Connecting the print fan

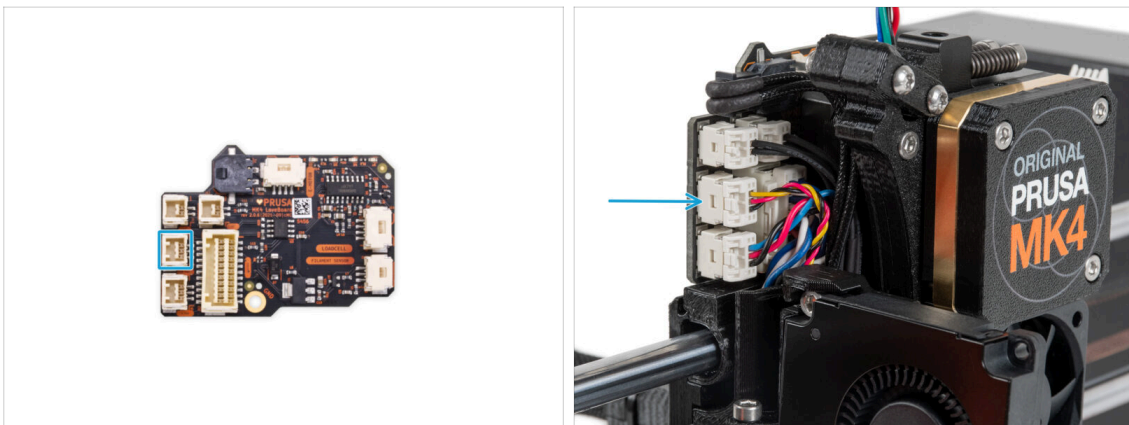

- ◆ Connect the print fan cable to the **middle slot** on the left side of the Loveboard.

STEP 37 LoveBoard: Wiring check

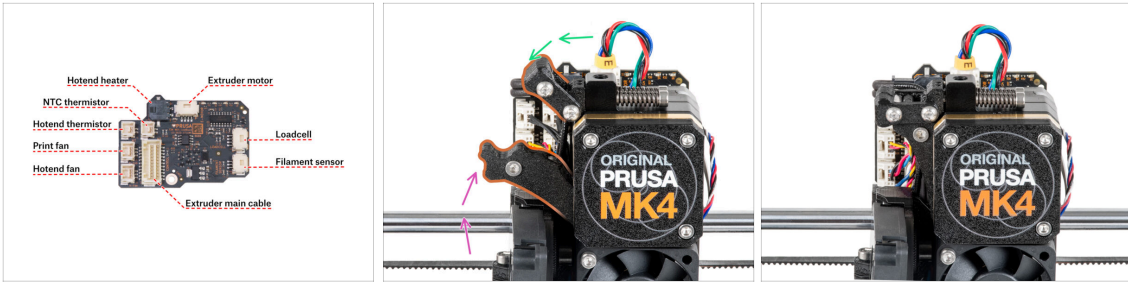

⚠ Before covering the electronics, check the connection of all cables. Click on high-resolution preview in the top left corner.

⬛ Close the idler mechanism before proceeding to the next step if you haven't already done so. Use the following sequence:

- 🟡** Close the extruder idler to the extruder
- 🟢** Close the idler-swivel and lock it over the extruder idler assembly

STEP 38 Covering the LoveBoard: parts preparation

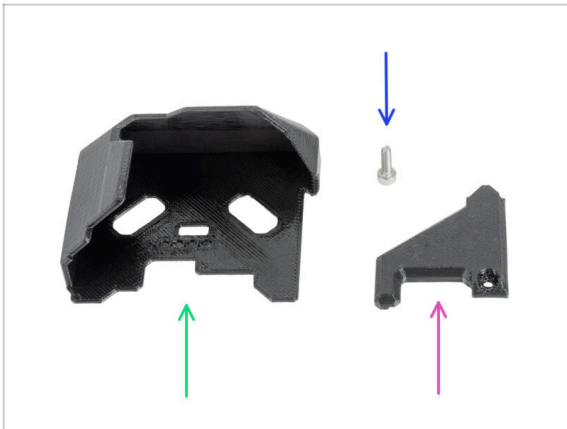

⬛ For the following steps, please prepare:

- 🟢** LoveBoard-cover (1x)
- 🟡** LoveBoard-cover-right (1x)
- 🟡** M3x10 screw (1x)

STEP 39 Covering the LoveBoard

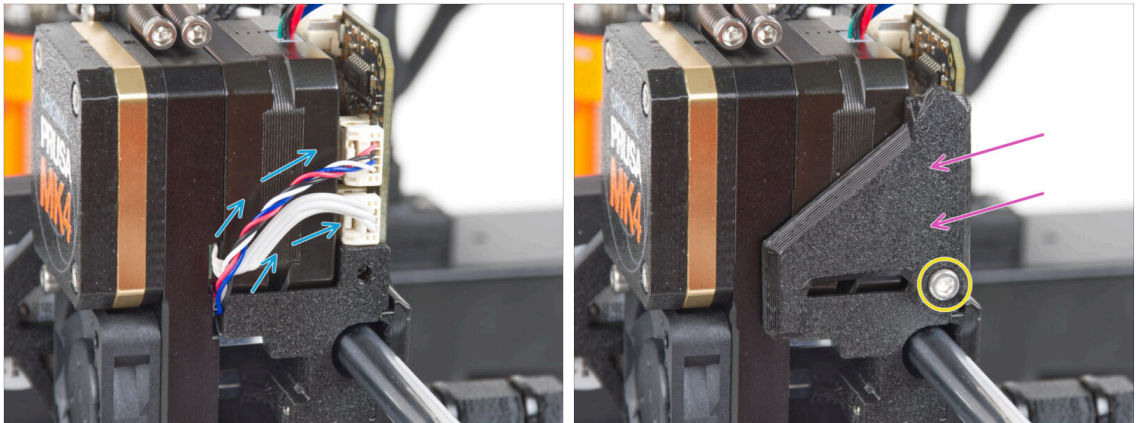

- ◆ Curve and arrange the cables on the right side of the extruder as you can see in the picture.
- ◆ Cover the cables with the LoveBoard-cover-right.
 - ⚠ **Do not pinch the cables!**
- ◆ Secure it with the M3x10 screw.
 - ⚠ **Make sure the LoveBoard-cover-right fits snugly against the right side of the extruder.** If not, it may cause the X-axis test to fail during the self-test because it will prevent the X-carriage assembly from moving all the way to the right.

STEP 40 Covering the LoveBoard

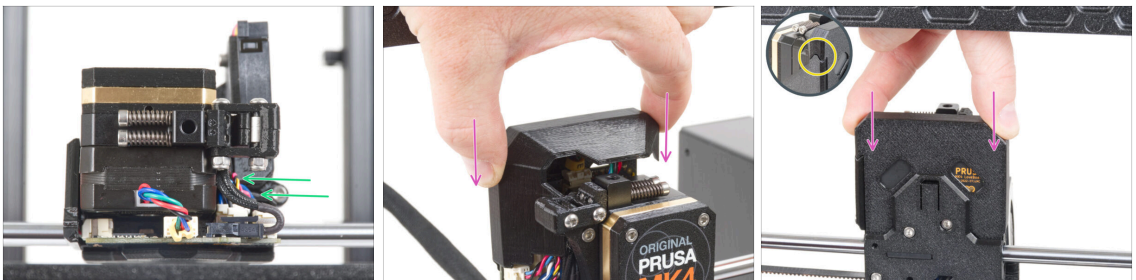

- ◆ Push all cables to the extruder to make more space around them. See the picture.
- ◆ Slide the Loveboard-cover on the extruder. And push it all the way down.
 - ⚠ **Be careful not to pinch any cables.**
- ◆ Ensure that the two plastic covers fit together perfectly.

STEP 41 Tensioning the X-axis belt

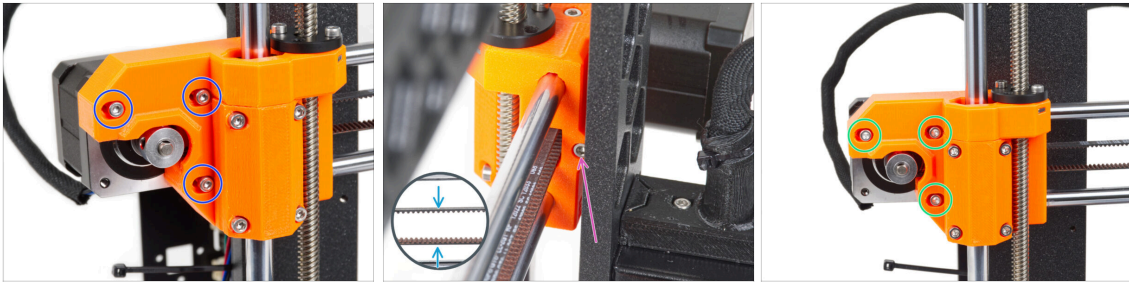

- i** In this step, we will finish tensioning the belt. Please read the instructions first, your belt might have proper tension already, then there is no need for additional screw adjustment.
- ◆** First, slightly release all the screws holding the motor, otherwise, the "tensioner" won't work (the motor must be able to move).
- ◆** Using ball-end Allen key start tightening the screw on the rear side of the X-end-motor, but after each turn or two check the tension in the belt.
- ◆** For the optimal performance, the belt must be a bit harder to press with your fingers. Move the extruder all the way to the X-end-idler and try the belt tension in the middle of the X-axis.
- ◆** When you achieve optimal tension, please tighten the screws again.

STEP 42 Belt tension check

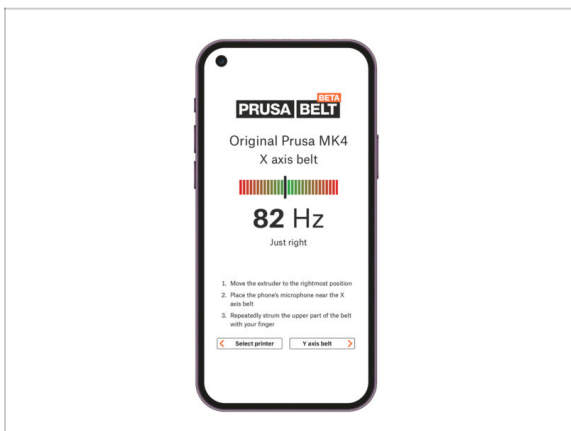

- i** This step is recommended, but optional. If you don't have a phone at your disposal, continue to the next step. You can do this check later on.
- ◆** To verify or fine-tune the X or Y-axis belt tension on your printer, visit prusa.io/belt-tuner and open up the webpage on your mobile device.
- ◆** Watch the instructional video on prusa.io/belt-tuner-video and fine-tune your X belt tension, if required.
- i** The belt tuner app was tested on multiple phones and should work across all most common phone manufacturers. However, in some rare cases it might not work as expected. Please state your brand and model in the comments below the step.

STEP 43 Testing the X-axis belt

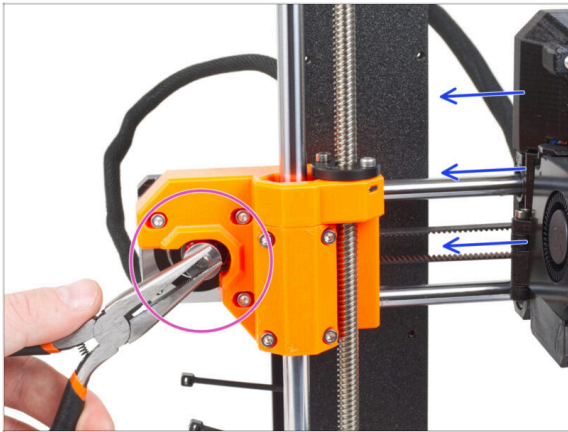

- Use the technique described below to test if the belt is properly stretched.
- Grasp and hold the flat part of the X motor shaft with pliers. This will prevent it from rotating in the pliers.
- Move the extruder towards the X motor. Don't use excessive force.
- If the belt is stretched properly, you should feel a resistance and the extruder won't move at all. If the belt is too loose, it will deform (create a "wave") and jump over the teeth on the pulley.

STEP 44 Haribo time!

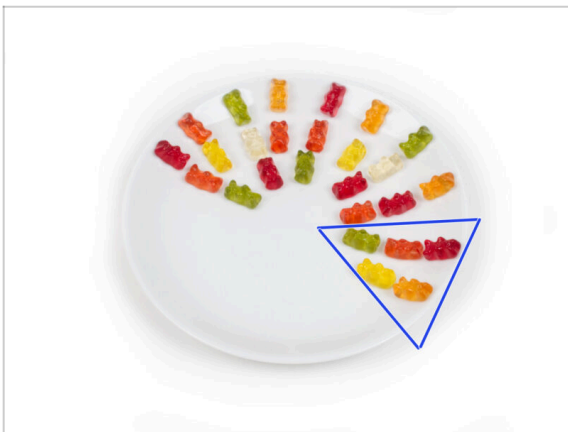

- Eat five gummy bears.
- ⓘ **Did you know that** gummy bears have a long shelf life, typically lasting for up to two years if stored properly in a cool and dry place. But don't do that now.

STEP 45 The extruder is assembled

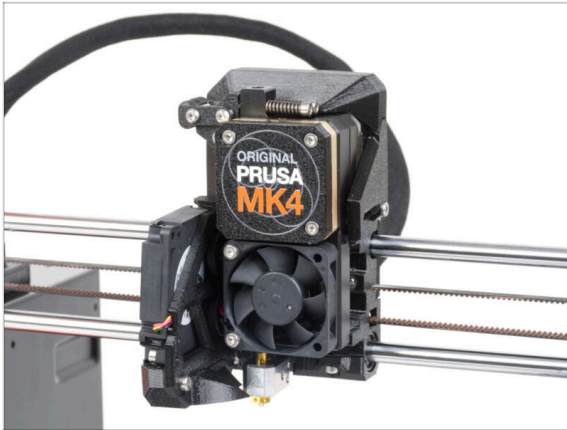

- ◆ That was tough. But we made it!
- ◆ Let's go the next chapter: **6. xLCD assembly**

6. xLCD assembly

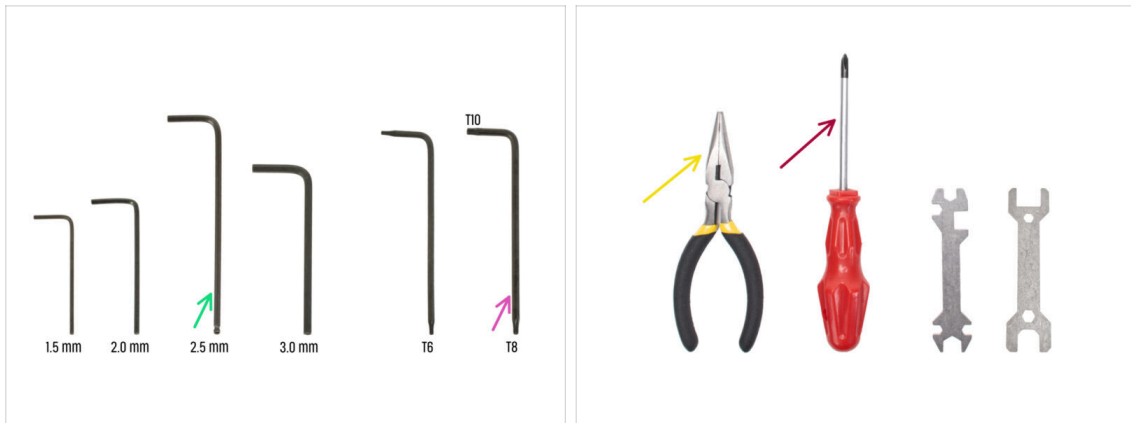

STEP 1 Tools necessary for this chapter

● **For the following steps, please prepare:**

- 2.5mm Allen key
- Needle-nose pliers for tightening and cutting zip ties
- Torx key T8/10
- Phillips screwdriver

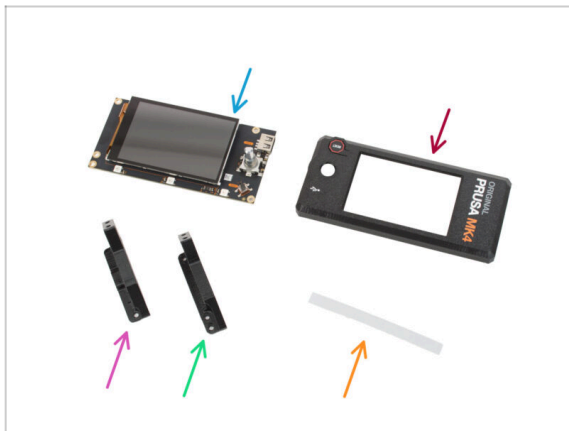
STEP 2 xLCD assembly: parts preparation (part 1)

● **For the following steps, please prepare:**

- xLCD (1x)
- ⚠ Remove the protective film from the xLCD screen.
- xLCD-cover (1x)
- xLCD-support-right (1x)
- xLCD-support-left (1x)
- xReflector sticker set (1x)
- ⓘ The list continues in the next step...

STEP 3 xLCD assembly: parts preparation (part 2)

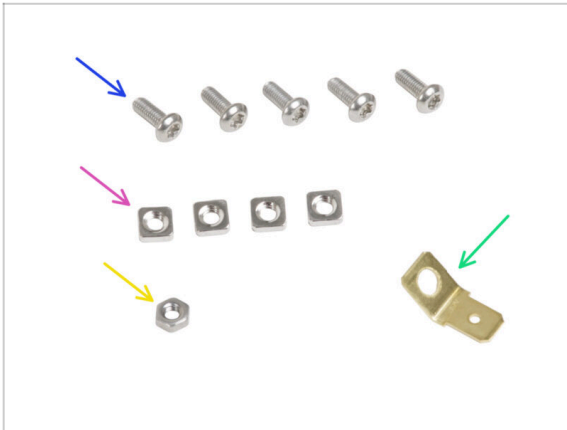

- M3x8rT screw (5x)
- M3nS nut (4x)
- PE Faston 6.3x0.8 (1x)
- M3n nut (1x)

STEP 4 xLCD assembly: inserting the square nuts



- Insert two M3nS nuts into the xLCD-support-left and xLCD-support-right.

STEP 5 Installing the xReflector sticker

- ◆ Peel off one of the individual adhesive xReflector sticker.
 - ⓘ If the sticker is damaged during peeling, there is an extra sticker in the SPARE package.
- ◆ Position the xReflector sticker strip so that it lines up with one side and both the edges of the "gutter" in the xLCD-cover. Continue to lay down the xReflector sticker strip towards the other side of the gutter.
- ◆ Press the xReflector sticker strip all the way into the gutter so it adheres to the xlcd-cover.

STEP 6 Assembling the xLCD

- ◆ Insert the M3n nut into the corresponding opening in the xLCD-cover.
 - ◆ Tip: for better insertion of the nut, screw the nut onto the tip of one of the longer screws and push it into the hole. Then remove the screw.
- ◆ Place the xLCD-support-right onto the USB-connector-side of the xLCD board. Notice there is a small hook that goes around the circuit board.
- ◆ Line up the hole in the plastic part with the hole in the xLCD board.

STEP 7 Assembling the xLCD-support-right



- ◆ Insert the xLCD with the xLCD-support-right still hooked on, into the xLCD-cover. Note the recess for the xLCD-support-right in the xLCD-cover. The support must perfectly fit into the recess.
- ⓘ Make sure the hook on the xLCD-support-right holds onto the xLCD now. Otherwise, you won't be able to attach it later.
- ◆ Secure the xLCD-support-right and the xLCD board with two M3x8rT screws.

STEP 8 Assembling the xLCD-support-left

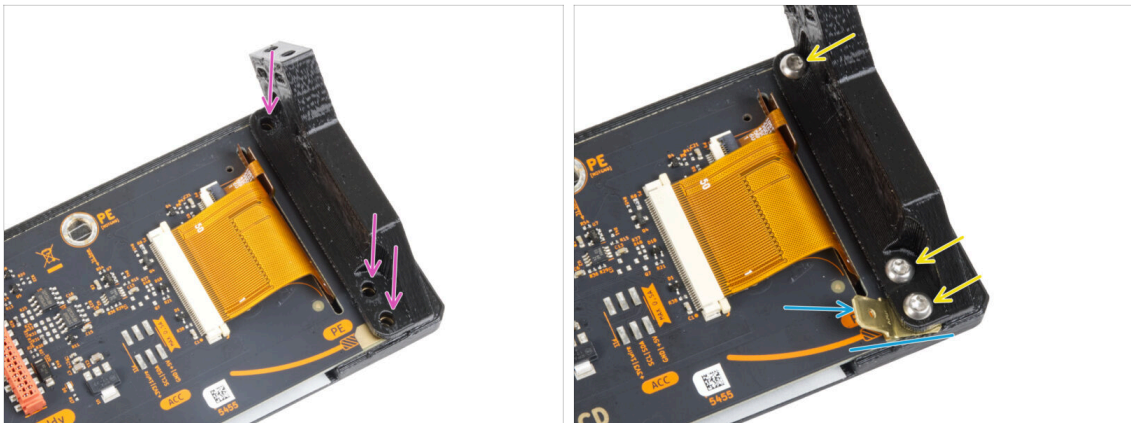

- ◆ Attach the xLCD-support-left on the xLCD board and align it with three holes in the board.
 - ◆ Insert the PE Faston between the xLCD-support-left and the xBuddy board. Align it with the hole and point the PE Faston slightly diagonally as you see in the picture.
 - ◆ Secure all parts together with three M3x8rT screws.
- ⚠ **Avoid scratching the xLCD board while tightening the screws.**

STEP 9 Attaching the xLCD assembly: parts preparation

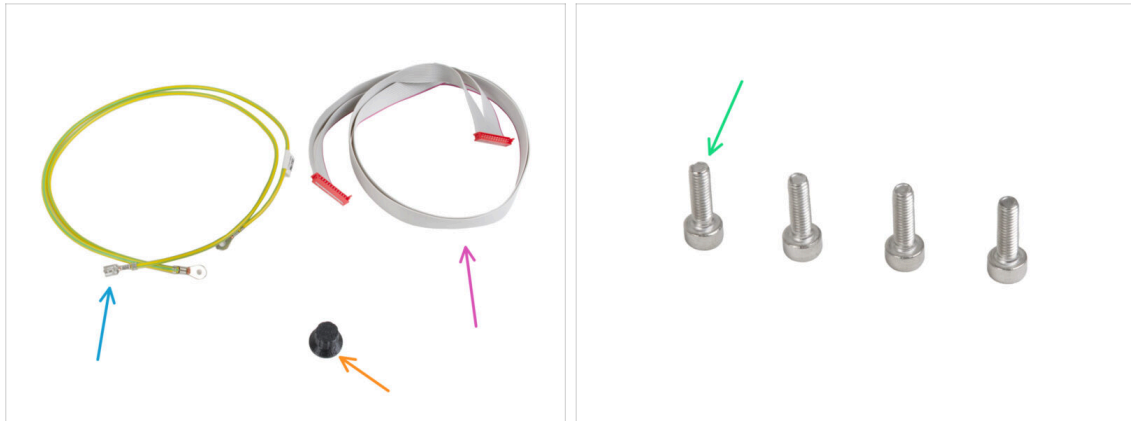

● For the following steps, please prepare:

- PE cable 460/420 mm (1x)
- xLCD cable (1x)
- xLCD-knob(1x)
- M3x10 screw (4x)

STEP 10 Connecting the PE cable

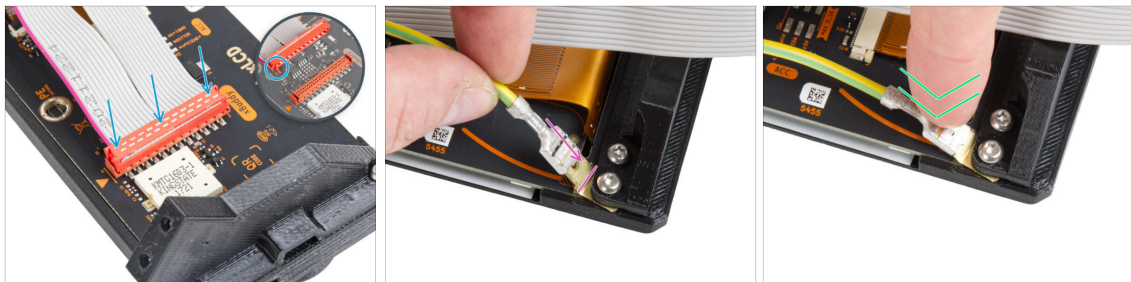

- Connect the xLCD cable to the xLCD board. Note the safety latch on the xLCD cable connector. It must be plugged into the side of the xLCD slot marked with the orange triangle on the board.
- ⚠ **Make sure the xLCD cable is connected in the same orientation as seen in the picture. Otherwise, your display won't work**
- Take the end of the PE cable with square connector. Slide the connector onto the PE Faston all the way down.
- Bend the PE Faston down slightly so that it does not protrude too far from the back of the display. Curve the cable according to the drawing on the board.

STEP 11 Attaching the knob



- Attach and push the xLCD-knob onto the xLCD encoder pin.
- ⓘ The orientation of the knob does not matter.

STEP 12 Attaching the xLCD assembly

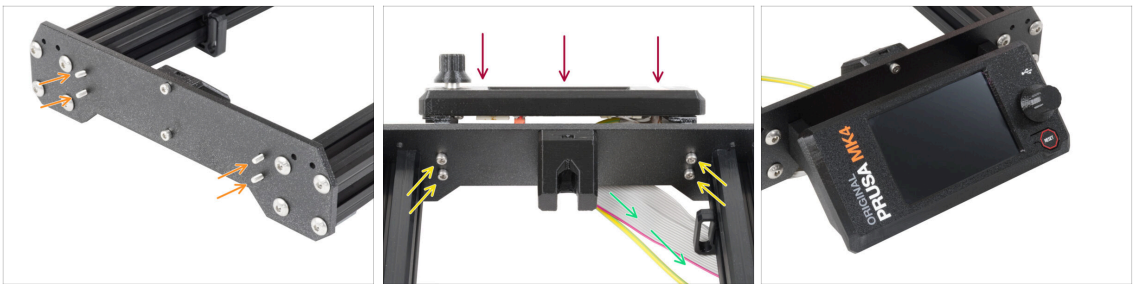

- There are four holes in the front plate of the printer's frame. Insert four M3x10 screws through each of them from the inner side.
- Attach the xLCD assembly onto the front plate. The screws should fit into the corresponding openings in the xLCD assembly.
- Guide the xLCD and PE cables under the front plate to the frame.
- Tighten up all four screws.

STEP 13 Guiding the xLCD cable

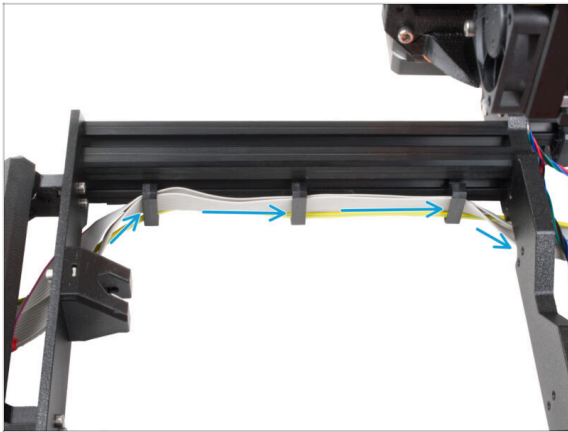

- ◆ Guide both cables through the cable clips on the inside of the frame.

STEP 14 Connecting the PSU: parts preparation

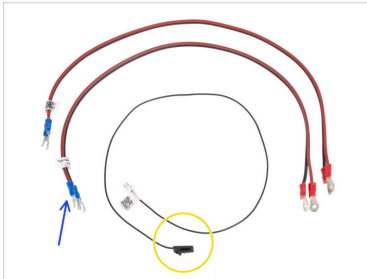

◆ For the following steps, please prepare:

- ◆ PSU-cover (1x)
- ◆ M3x10 screw (2x)
- ◆ xBuddy power cable (2x)
- ◆ Power panic cable (1x)
- ◆ Zip tie (3x)

STEP 15 Connecting the PSU: PE cable

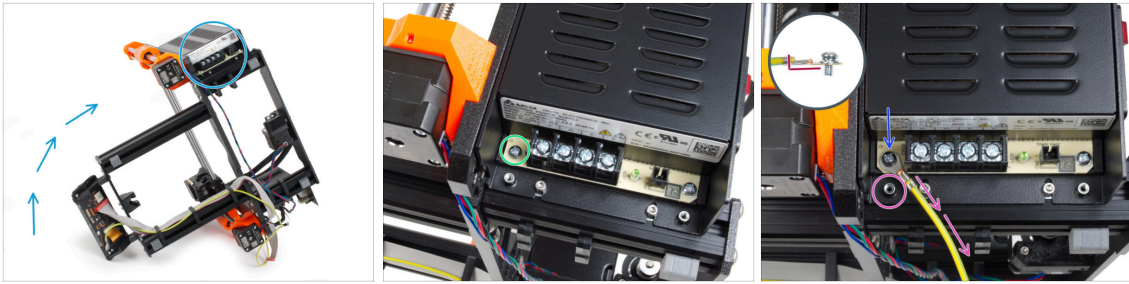

- ◆ Place the printer so that you have easy access to the bottom side of the PSU.
- ◆ Remove the left screw on the PSU circuit board. Note there is a washer on the screw. Do not throw the screw away, you will need it later.
- ◆ Place the end of the PE cable into the same place you have removed the screw. Secure the cable by re-using the screw together with the washer.
- ⚠ **Note the correct orientation of the PE cable connector.**
- ◆ Guide the PE cable so that it does not interfere with the threaded column under the PE connector.

STEP 16 Power cables info

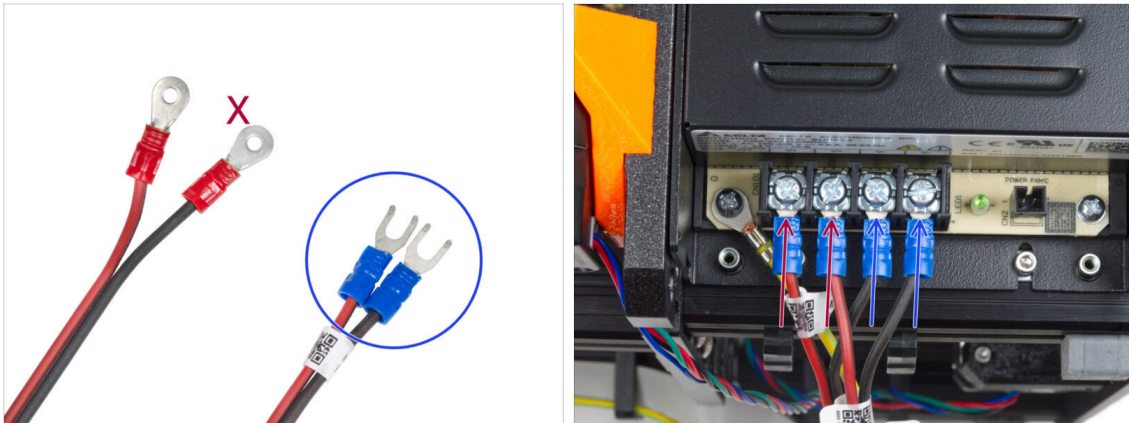

- i** In the following steps, we will be connecting the power cables one by one. The terminal screws are installed on the PSU already. Loosen them but **don't remove them completely** so they don't get mixed up with the other type of screws used on the xBuddy board side of the cable. Each of the two power cables has two leads. One has a prevailing **red color = positive / +**
One has a prevailing **black color = negative / -**
- ◆** Note that the power cables have different connectors on each end. For now, prepare the blue connectors.
- ◆** **Note that the polarity of the terminals on the PSU is:**

 - ◆** Positive (V+)
 - ◆** Positive (V+)
 - ◆** Negative (V-)
 - ◆** Negative (V-)
- i** The red cable (positive) may have a black stripe on it. Similarly, the black cable (negative) can have a red stripe on it.
- ⚠** **Do not connect any cables yet, wait until you have prompted.**

STEP 17 Connecting the PSU

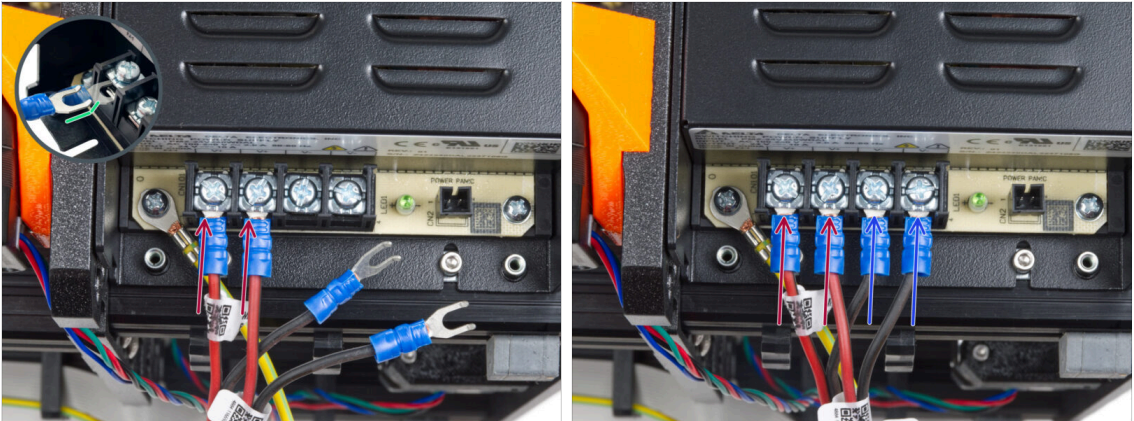

- Take two **RED** wires and slide the fork connectors all the way into the first two (positive) terminals from the left on the bottom of the PSU. Make sure the steel washer is above the "fork" connector.
 - Point the bent part of the fork upwards.
 - Tighten the terminal screw firmly.
 - i Keep in mind some parts are made out of plastic. When tightening each of the terminal screws, proceed carefully.
 - Take the **BLACK** wires and slide them all the way into the last two (negative) terminals. Make sure the steel washer is above the "fork" connector.
 - Tighten the terminal screw firmly.
 - ⚠ **Check all the connections again!** The red wire is in the first slot and black in the third. Make sure that cables are tightened properly. Otherwise, there is a risk of a damage to the printer and its surroundings!

STEP 18 Connecting the power panic

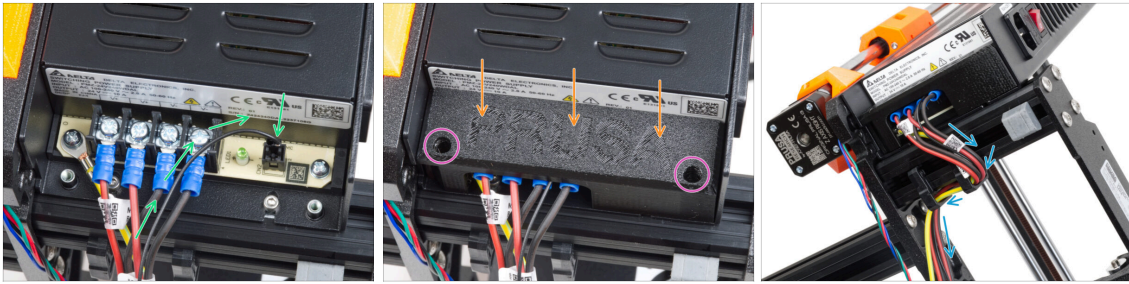

- ◆ Connect the power panic cable into the PSU. Use the side with the black connector at the end.
- ◆ Place the psu cover over the power terminals. Make sure the "PRUSA" logo is facing upwards.
- ⚠ **Make sure the cover is seated properly and no cable is being pinched underneath.**
- ◆ Attach the cover by using the two M3x10 screws through the marked openings. Note the openings are quite deep.
- ⚠ **Check all the connections again! The red wire is in the second slot and black in the fourth. Make sure that all the cables are properly tightened. Otherwise, there is a risk of damage to the printer and its surroundings.**
- ◆ Take a look from the bottom of the PSU and guide all the PSU cables through the cable clips according to the picture.

STEP 19 Guiding the Z motor right cable

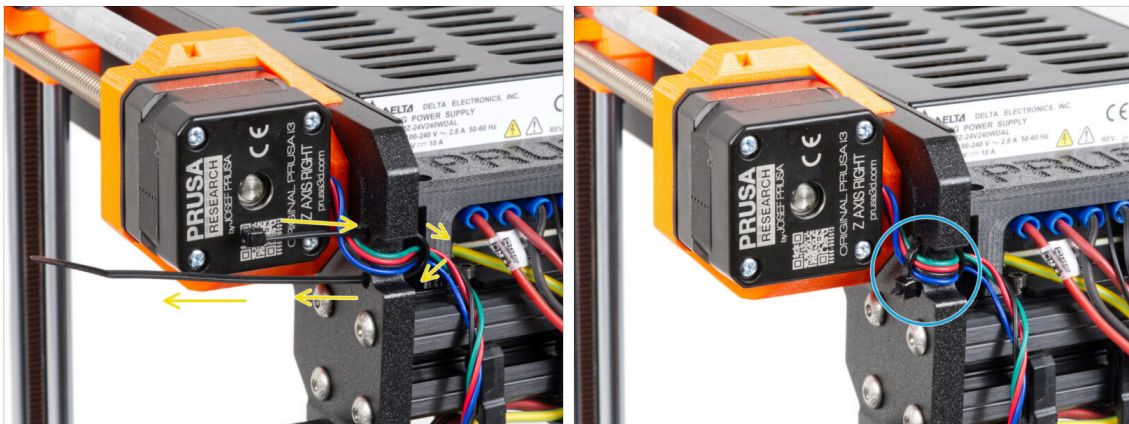

- ◆ Slide the zip tie through the circular holes in the frame to create a loop on both sides of the frame so that the cable goes through both the loops.
- ◆ Start tightening the zip tie so it is snug and holds the wires on both sides. Be careful not to over-tighten the zip tie as it could damage the wires. Cut off the remaining part of the zip tie very carefully.

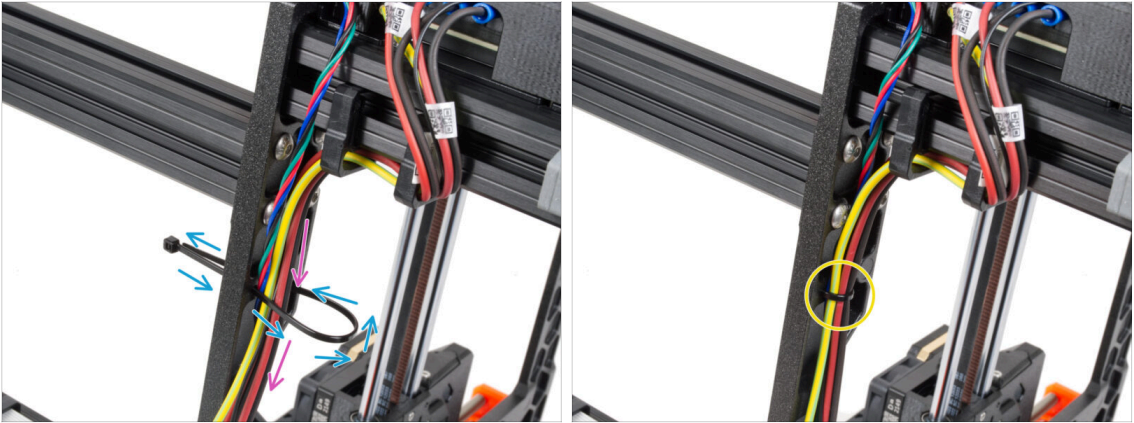
STEP 20 Guiding the power cable bundle

- ◆ Continue downwards and using another zip tie create the next loop.
- ◆ Guide the Z-axis cable and all cables from the PSU through the zip tie.
- ◆ Place the PE and power cables at the bottom of the bundle.
- ◆ Push the cable gently in the zip tie and tighten it so it is snug and holding the wires. Be careful not to over tighten the tie as it can cut the wires. Cut the remaining part.

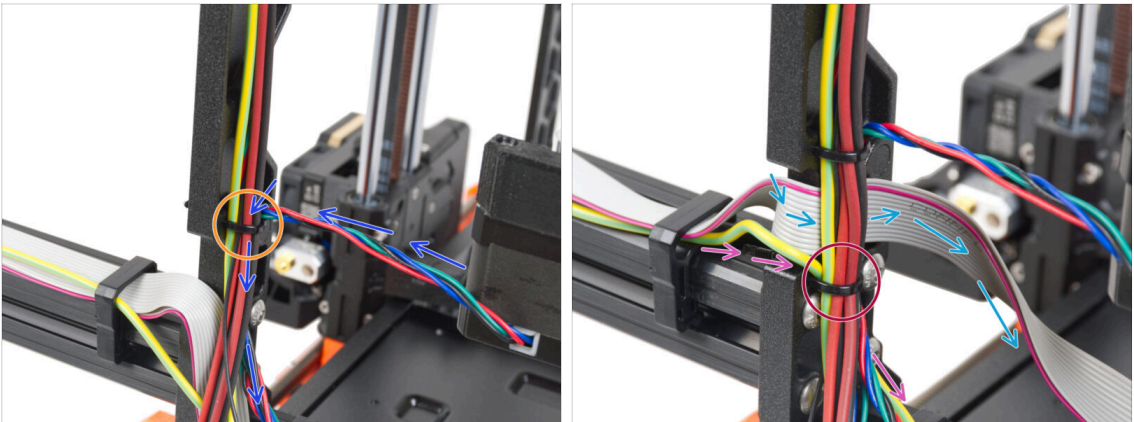
STEP 21 Guiding the power cables

- ◆ Continue guiding the cables toward the xBuddy. Include the Y motor cable into the bundle.
- ◆ Secure it with another zip tie to the frame.
- ◆ Carefully guide and fold the xLCD cable under the cable bundle. **Do not include the xLCD cable in the cable bundle.** Leave it free for now.
- ◆ Guide the PE cable from the xLCD through the cutout in the frame and include it in the cable bundle.
- ◆ Secure the cable bundle with the zip tie.

STEP 22 Connecting the X and Y motor cables

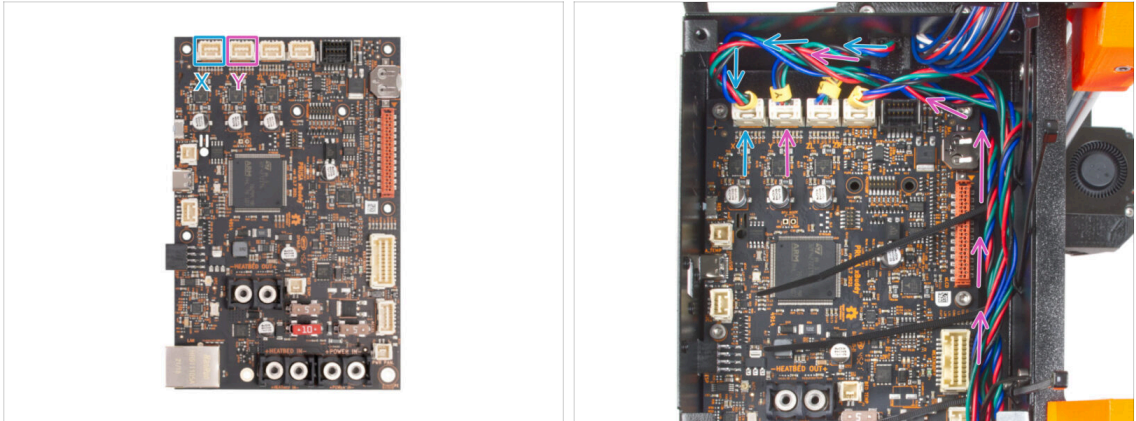

- ◆ Connect the X motor cable to the first slot from the left on the top of the xBuddy.
- ◆ Connect the Y motor cable to the second slot from the left on the top of the xBuddy. Guide the cable alongside the xBuddy box over the zip ties.

STEP 23 Connecting the PSU cable: parts preparation

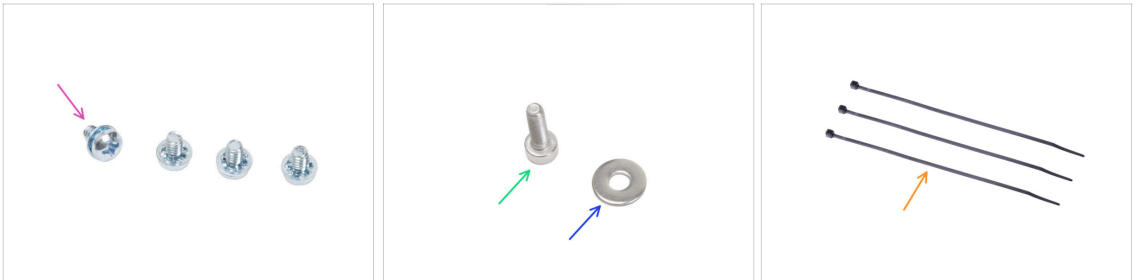

◆ For the following steps, please prepare:

- ◆ Terminal screw 6/32" (4x)
- ◆ M3x6 screw (1x)
- ◆ M3w washer (1x)
- ◆ Zip tie (3x)

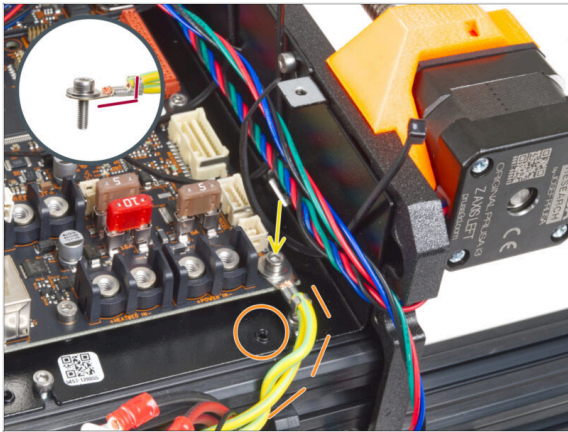
STEP 24 Connecting the PSU cables: PE cable

- ◆ Attach the PE cable connector to the right lower screw hole in the xBuddy box. Secure the cable with the M3w washer and the M3x6 screw. Tighten the screw firmly.
- ⚠ **Note the correct orientation of the PE connector.**
- ◆ Guide the PE cable so that it does not interfere with the threaded hole under the xBuddy board.

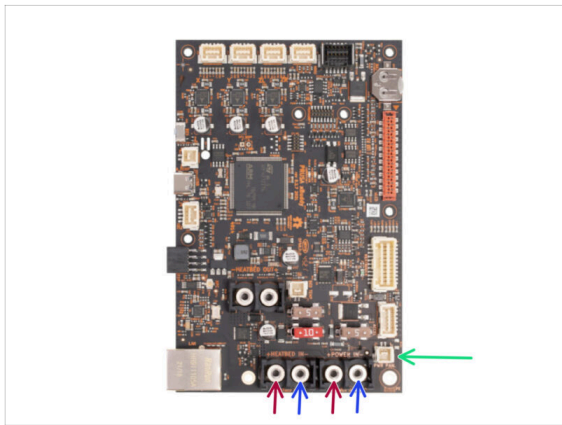
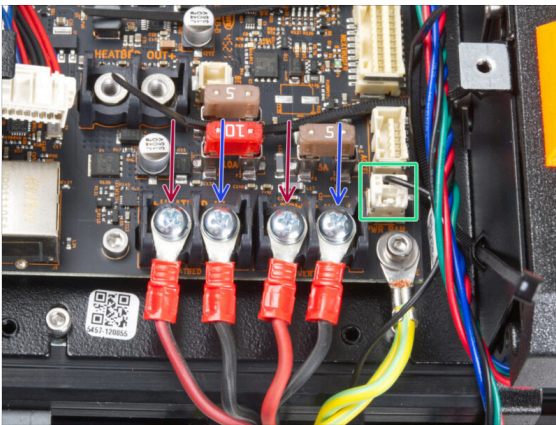
STEP 25 Connecting the PSU cables:

- ◆ Connect the power panic cable to the white connector on the bottom of the xBuddy board.
- ◆ **Connect the PSU cables into the xBuddy board in this order (starting from the left). :**
 - ◆ Red power cable (positive)
 - ◆ Black power cable (negative)
 - ◆ Red power cable (positive)
 - ◆ Black power cable (negative)
- ◆ Secure all power cable connectors with the terminal screws. Tighten the screws firmly.
- ⚠ **Verify the correct placement of the cables comparing it to the picture. This is crucial! Incorrect wiring may cause damage to your printer!**

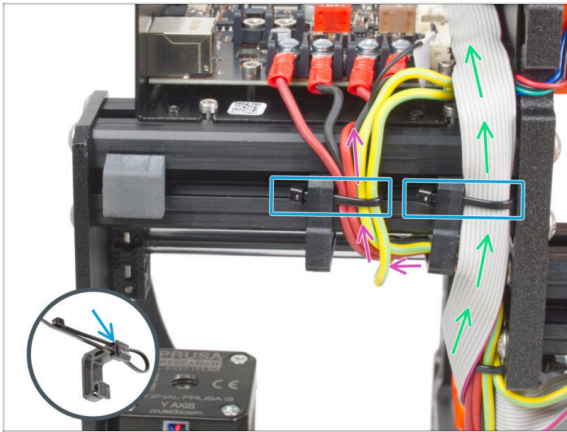
STEP 26 Securing the PSU cables

- ◆ **Divide the cable bundle into three paths:**
 - ◆ Guide the cables from the PE cables, PSU cables and Power Panic cable around the left cable clip from the right side
 - ◆ Guide the xLCD cable and motor cables in between the right cable clip and the frame
- ◆ Secure all cable paths with the zip tie to the cable clip. See the detail showing how to push a zip tie through the cable clip.

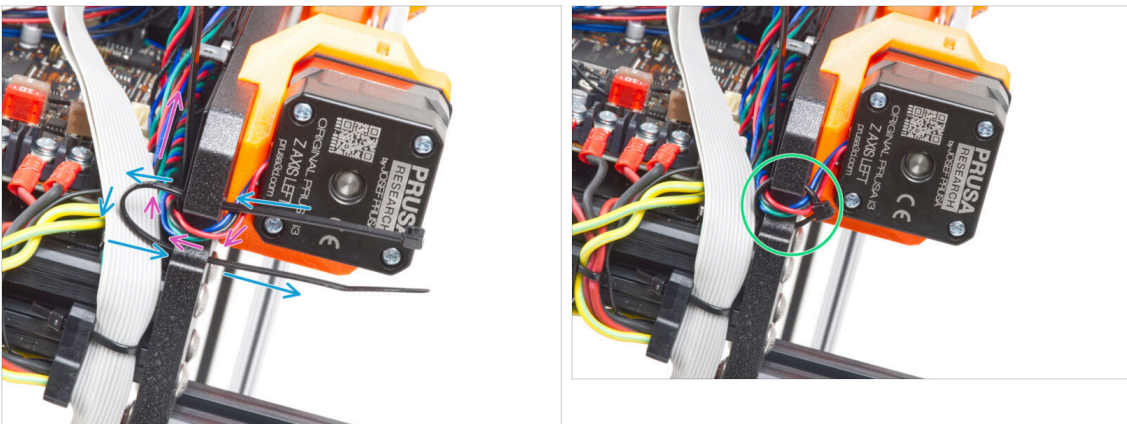
STEP 27 Guiding the Z motor left cable

- ◆ Push the zip tie through the frame under the Z motor left.
- ◆ Guide the Z motor left cable through the cutout in the frame to the xBuddy box.
- ◆ Carefully tighten the zip tie. Cut off the excess of the zip tie.
- ⚠ **Do not overtighten the zip tie, it may fatally damage the cable.**

STEP 28 Connecting the xLCD cables

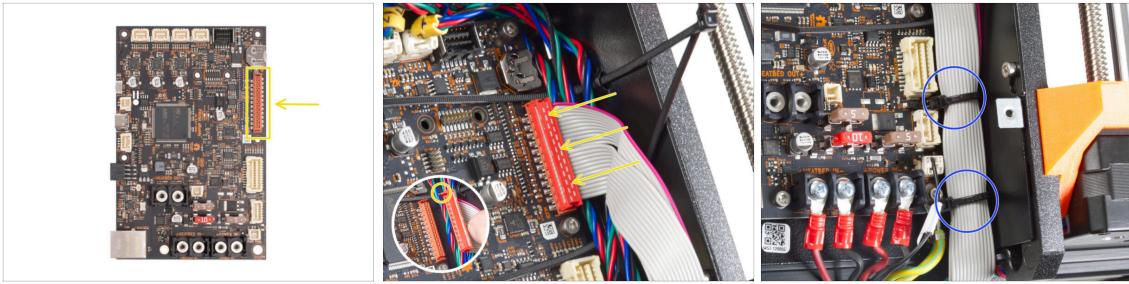

- ◆ Connect the xLCD to the slot on the right side of the xBuddy. Note the safety latch on the xLCD cable connector. The latch must fit into the upper side of the connector.
- ⚠ **Make sure that all the cable guiding over the zip ties in the xBuddy box, not under the zip ties.**
- ◆ Arrange the xLCD cable like in the picture. The xLCD must covering the cable bundle. Tighten the cable bundle with the first two zip ties in the bottom of the xBuddy box. **Do not overtighten the zip ties!**

STEP 29 Connecting the extruder main cable

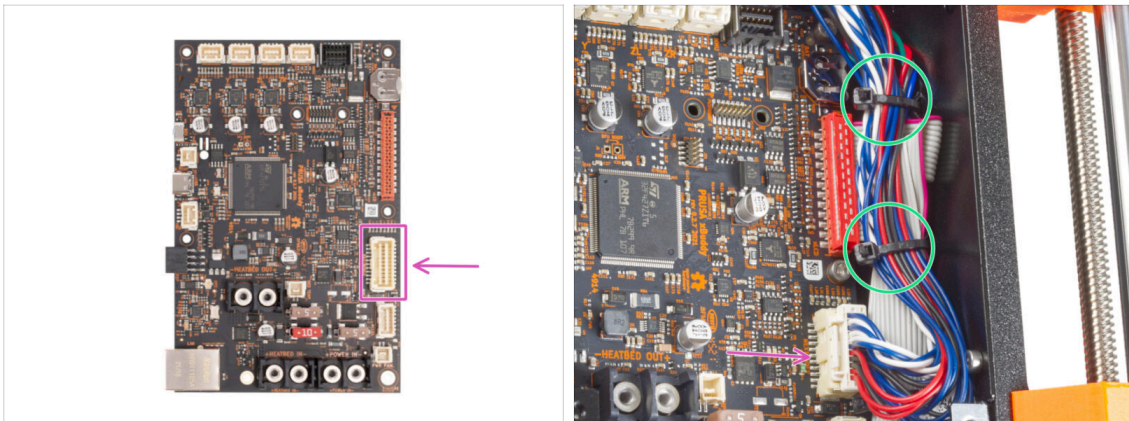

- ◆ Connect the extruder main cable to the slot in the right side of the xBuddy.
- ⚠ **Make sure that all the cable guiding over the zip ties in the xBuddy box, not under the zip ties.**
- ◆ Arrange the cable according to the picture. Tighten the cable bundle (extruder main cable and the motor cables) with the two upper zip ties. **Do not overtighten the zip ties!**

STEP 30 Time for energy delivery!



- ◆ It was almost like rocket science, but you did it! Take six gummy bears.
- ⓘ **Did you know that** some gummy bear manufacturers offer sugar-free versions of the candy, which are sweetened with artificial sweeteners like maltitol or stevia.

STEP 31 Almost there!



- ◆ Wasn't as hard, right? You are almost there!
- ◆ Just compare the xLCD assembly and the cable management to the pictures.
- ◆ Let's go the next chapter: **7. Y-carriage & Heatbed assembly**

7. Y-carriage & Heatbed assembly



STEP 1 Tools necessary for this chapter

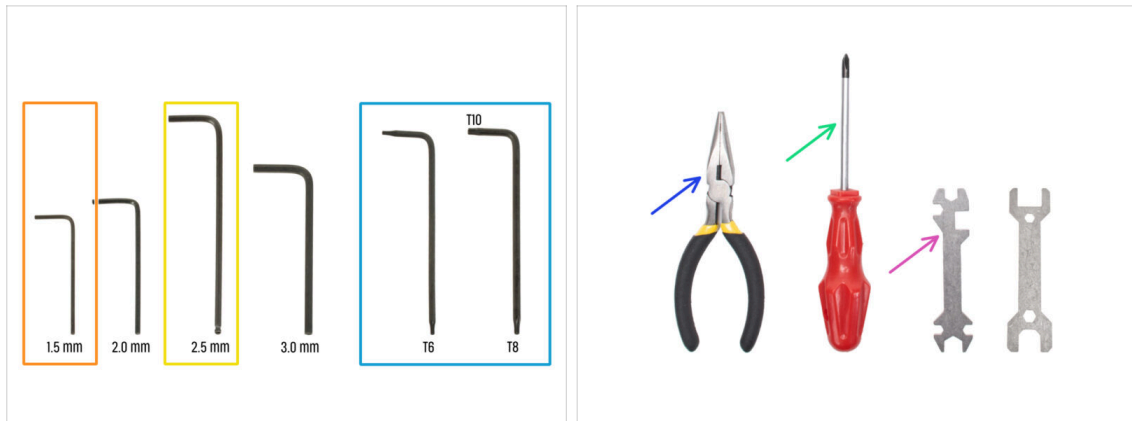

● For this chapter, please prepare:

- 1.5mm Allen key
- 2.5mm Allen key
- Torx T8/10 key
- Needle-nose pliers
- Phillips screwdriver PH2
- Universal wrench

STEP 2 Heatbed cable assembly: parts preparation

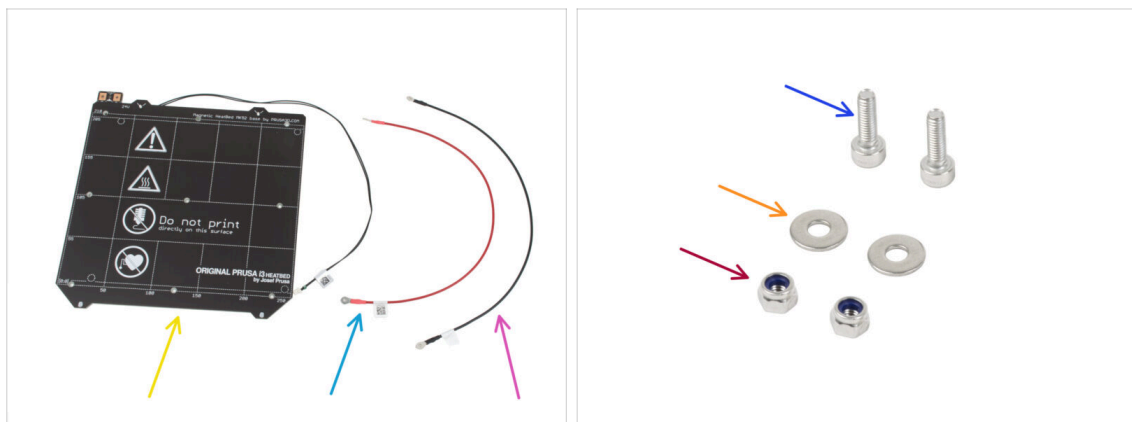

● For the following step please prepare:

- Heatbed MK52 24V (1x)
- Heatbed cable red (1x)
- Heatbed cable black (1x)
- M3x10 screw (2x)
- M3w washer (2x)
- M3nN nut (2x)

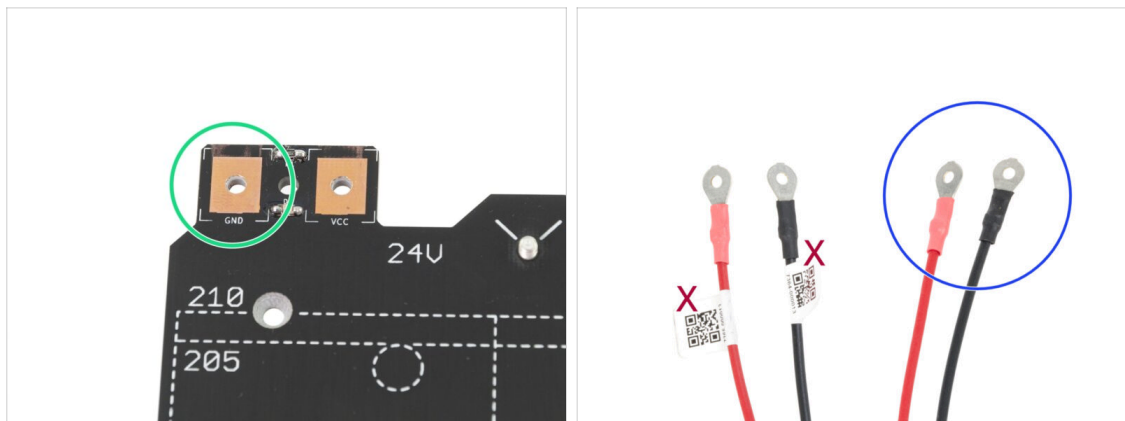
STEP 3 Heatbed cable assembly (part 1)

- **IT IS IMPORTANT** to connect the power cable correctly. Before you start the assembly have a look at the pins. The one on the left with "GND" sign must be connected to the **BLACK WIRE**.
- Take both Heatbed cables. Note the label on each cable. For the following steps, prepare the ends of the cables **without the label**.

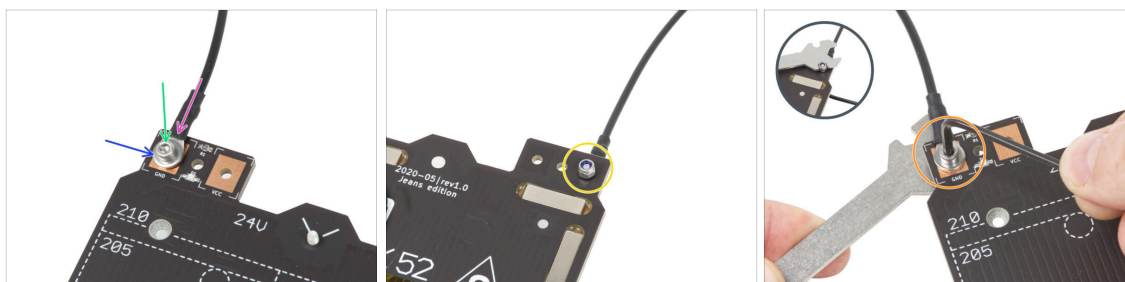
STEP 4 Heatbed cable assembly (part 2)

- Place the black wire above the pin with "GND" sign. **Use the end of the cable that is not labeled with QR code.** The QR code must be at the other end.
- Place the M3w washer above the round cable connector.
- Press the M3x10 screw through all parts.
- Hold the screw and carefully turn the heatbed upside down.
- Attach the M3nN nut onto the M3x10 screw and tighten it slightly.
- Turn the heatbed back around. Using the universal wrench and the Allen key, tighten up the screw. We will adjust the cable position later on, **therefore do not tighten the screw too firmly yet.**

STEP 5 Heatbed cable assembly (part 3)

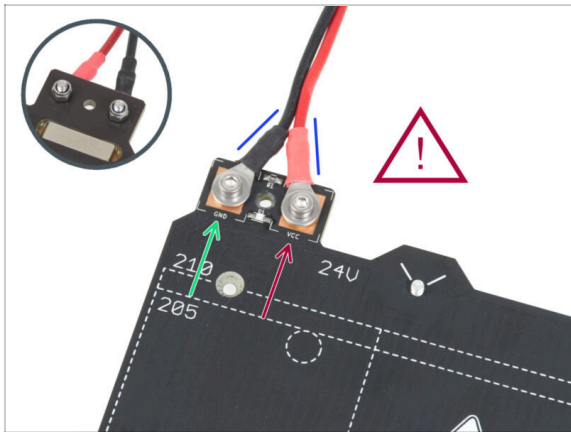

- Repeat this procedure for the second (Red / + / VCC) wire. **Use the end of the cable that is not labeled with QR code.** The QR code must be at the other end.

⚠ Before proceeding further, please check again that:

- GREEN** wire must be connected to the "GND"
- BROWN** wire must be connected to the "VCC"
- The cable cover, which will be applied later requires the connectors to be slightly inclined towards each other. Press them gently, but leave a gap between them.
- ⚠ Now, tighten both screws firmly using the Allen key and the wrench. Maintain the position of the connectors while tightening.**

STEP 6 Covering the heatbed cables: parts preparation

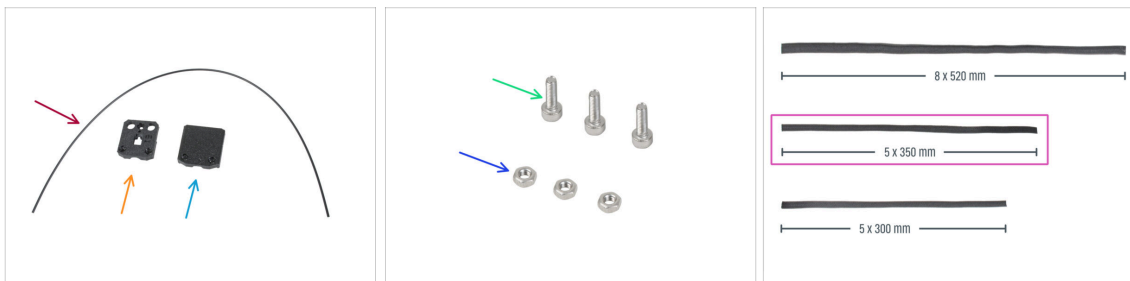

- For the following steps, please prepare:**

- BROWN** Nylon 2x380 mm (1x)
- ORANGE** heatbed-cable-cover-bottom
- BLUE** heatbed-cable-cover-top
- GREEN** M3x10 screw (3x)
- BLUE** M3n nut (3x)
- PINK** Textile sleeve 5x350 (1x)

STEP 7 Assembling the heatbed-cable-cover-bottom

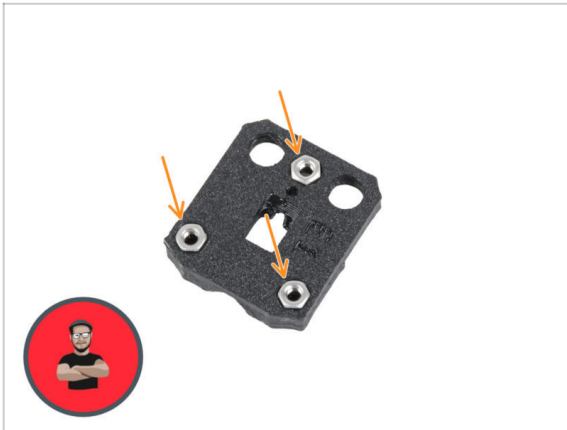

- ◆ Insert three M3n nuts into the shaped openings in the heatbed-cable-cover-bottom.
- i Use the screw pulling technique.

STEP 8 Assembling the heatbed-cable-cover: nylon filament

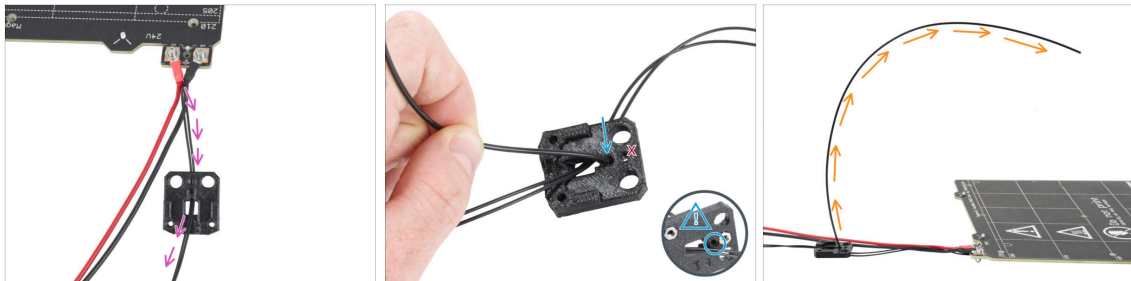

- ◆ Place the heatbed-cable-cover-bottom like in the picture. Push the heatbed thermistor cable through the heatbed-cable-cover-bottom.
- ◆ Insert the nylon filament into the hole in the heatbed-cable-cover-bottom. Don't let the nylon filament stick out too much on the other side. When inserting the nylon filament, **ensure that the filament does not damage the thermistor cables under the printed part.**
- ◆ Orient the curve of the filament as shown in the third picture.

STEP 9 Assembling the heatbed-cable-cover-bottom

- ◆ Slide the cable-cover-bottom under the heatbed cable connectors (M3nN nuts). See the correct orientation in the picture.
- ◆ Secure the cover with the M3x10 screw from the top. Tighten the screw firmly.

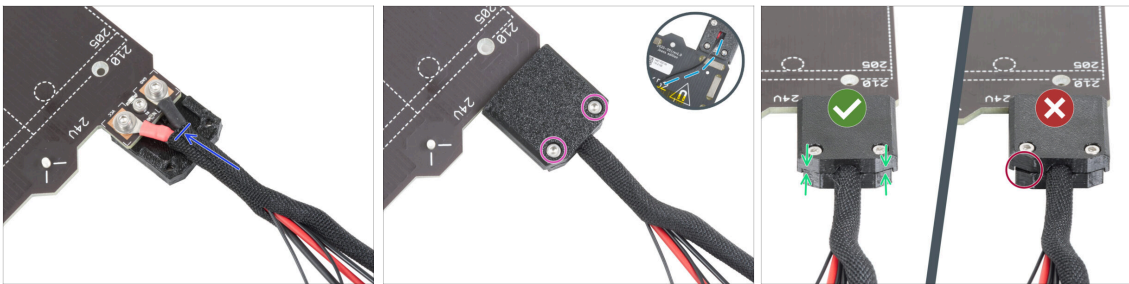
STEP 10 Assembling the heatbed-cable-cover-top

- ◆ Wrap the end of the cable bundle together with the nylon filament in the textile sleeve. Slide the sleeve as far towards the heatbed as possible.
- ◆ Attach the heatbed-cable-cover-top onto the junction and secure it with two M3x10 screws.
- ◆ On the bottom side, leave a slack on the thermistor cable for one finger to be pushed through.
- ◆ Make sure there is no big gap between both covers.

STEP 11 Wrapping the textile sleeve

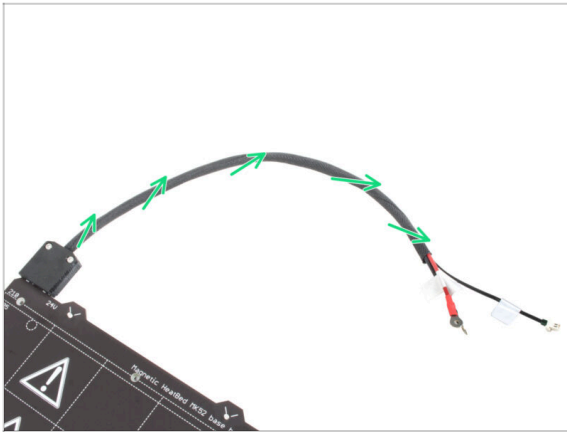

- Finish wrapping the cable bundle in the textile sleeve. And twist the sleeve, **not the cables**.

STEP 12 Assembling the Y-carriage: parts preparation

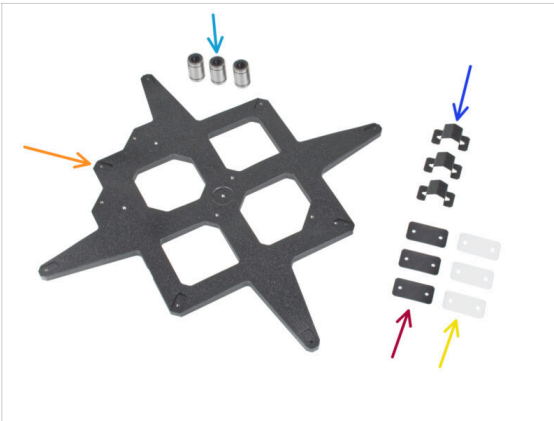

- For the following steps, please prepare:
- LM8UU bearing (3x)
- Y-carriage (1x)
- Bearing clip (3x)
- Rubber bearing pad 31x16x0.5 mm (3x)
- Plastic bearing pad 31x16x1 mm (3x)
- M3x8 screw (6x)

STEP 13 Y-carriage: parts preparation (lubricating)

◆ For the following steps, please prepare:

- ◆ Prusa lubricant applicator (1x)
- ◆ Prusa lubricant (1x) for LM8UU bearings
- ◆ Several paper towels to wipe oil and grease from the bearing surface.

⚠ **Each bearing must be lubricated before mounting on the printer. Follow these instructions carefully.**

STEP 14 Lubricating the bearing

ⓘ Use any piece of fabric as a pad to protect your working surface from grease.

⚠ **Make sure the bearing is clean inside.**

- ◆ Wipe the preservative oil off the bearing surface with a paper towel.
- ◆ It is necessary to lubricate all 4 rows of balls inside the bearing.
- ◆ Open the lubricant and pierce the hole in the tube with the tip in the cap.
- ◆ Screw the tube into the applicator.
- ◆ Carefully slide the entire bearing onto the applicator.

STEP 15 Lubricating the bearing

- Turn the tube and applicator clockwise until you feel a slight resistance. This means that the holes in the applicator are aligned with the ball rows.
- Gently press the tube to push the lubricant into the ball rows of the bearing.
- Look at the front of the bearing. When the applicator pushes the lubricant out (around the black gasket), stop pressing the tube. Hold the bearing with the other hand during the lubricating.
- ⚠ **The grease must be spread evenly over all four ball rows inside the bearing. There must not be too much grease, or too little. Take a closer look at the last picture.**
- Wipe off excess grease on the outside of the bearing with a paper towel.
- Use this procedure for all three bearings.
- ⓘ The bearings may leave excess grease on the smooth rods after their installation. Wipe off any residue with a paper towel.

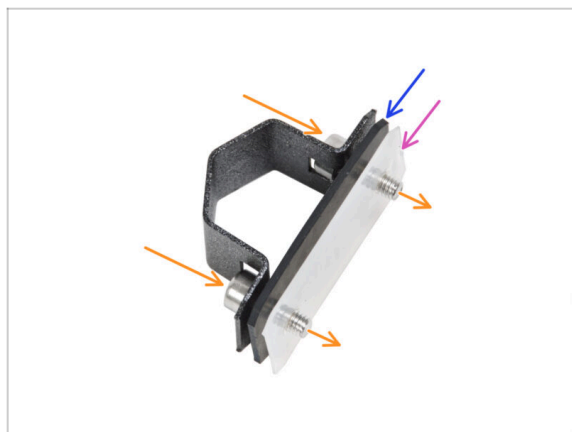
STEP 16 Assembling the bearing clips

- Push two M3x8 screws through the bearing clip.
- Insert the rubber bearing pad on the screws.
- Insert the plastic bearing pad on the screws.
- Repeat the same for the remaining two bearing clips.
- ⚠ **The order of the pads is crucial. Check the order on all three bearing clips.**

STEP 17 Installing the bearing on the Y-carriage

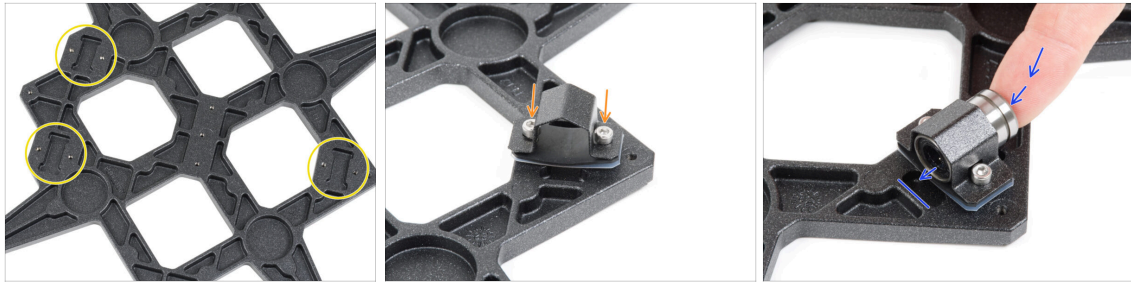

- ◆ Note the three pockets for bearings in the Y-carriage.
- ◆ Start with the side with the one pocket. Attach the bearing clip on the cutout.
- ◆ Insert the bearing into the bearing clip.

STEP 18 Aligning the bearing

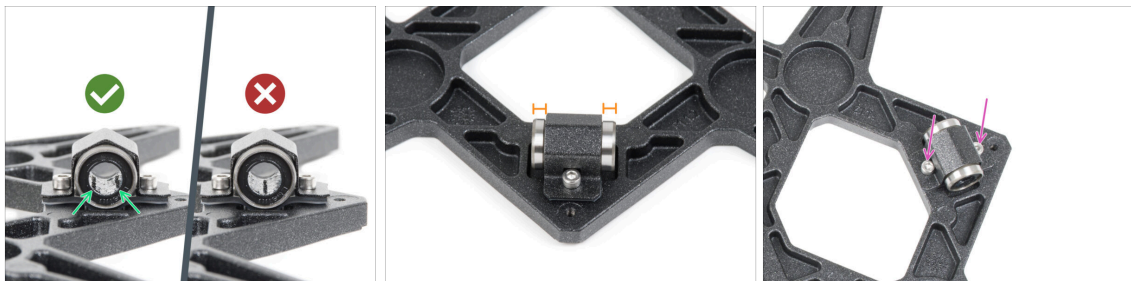

- ◆ **The correct bearing orientation:** When placing bearings onto the Y-carriage, **make sure that they are oriented as shown in the picture.** The tracks (rows of balls) have to be on the sides.
- ◆ Align the bearing so that it is centered on the bearing clip. Approximately the same piece of bearing should be visible on each side.
- ◆ Maintain the bearing position and slightly tighten both screws. Just barely to maintain its position and orientation. We will tighten the screws firmly later on.

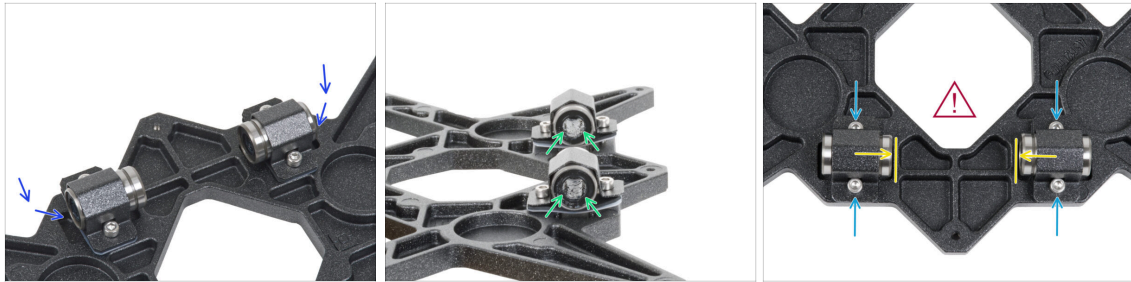
STEP 19 Installing the bearings on the Y-carriage

- ◆ Attach two bearing clips on the remaining two bearing pockets and push two bearings inside.
 - ◆ Orient both bearings so that the two rows of bearing balls have to be on the sides.
 - ◆ Unlike the previous bearing, position the bearings as close to the center of the Y-carriage as possible. **Beware, the bearings must not touch the edge of the pocket!**
- ⚠ **Correct bearing alignment is CRUCIAL.** Proceed carefully and make sure that **both bearings are as close to the center of the Y-carriage as possible and do not touch any pocket edge.**
- ◆ **Maintain the bearing's position** and slightly tighten the screws. Just barely to maintain the position and orientation of the bearings. We will tighten the screws firmly later on.

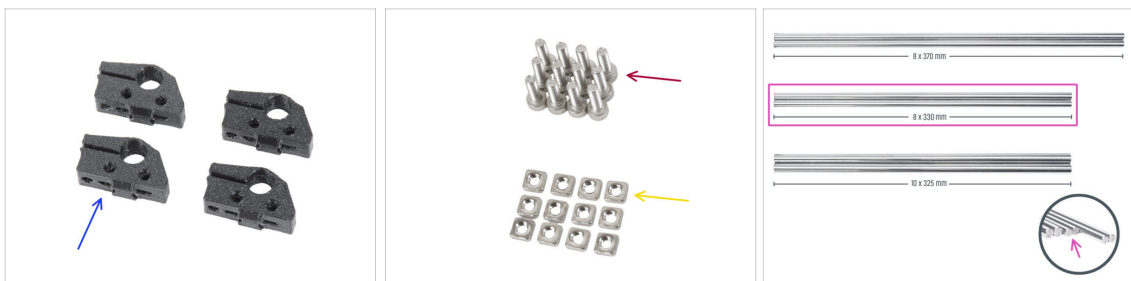
STEP 20 Y-axis: smooth rods holders

- ◆ **For the following steps, please prepare:**
- ◆ Y-rod-holder (4x)
 - ◆ M3x10 screw (12x)
 - ◆ M3nS nut (12x)
 - ◆ Smooth rod 8x330 (2x)

STEP 21 Preparing Y-rod-holder

- ◆ Take one Y-rod-holder and insert two M3nS nuts.
- ◆ Make sure you've pressed the nuts all the way in. You can use pliers, **BUT** be careful, you can damage the printed part.
- ⓘ In case you can't press the nuts in, don't use excessive force. First, check if there isn't any obstacle in the nut trap.
- ◆ Insert one M3nS nut from the side of the Y-rod-holder.
- ◆ Ensure and adjust the alignment of each nut with the 2mm Allen key.
- ◆ Repeat for the remaining Y-rod-holders.

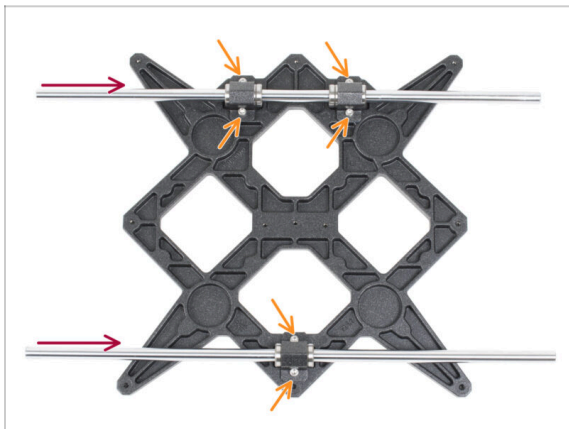
STEP 22 Inserting smooth rods into Y-carriage

- ⚠ **NOW, PLEASE BE VERY CAREFUL!** Gently insert the rod straight into the bearings, do not apply too much force and do not tilt the rod!
- ⓘ In case you manage to push out some balls from the bearings by accident, please count the balls. Without one or two balls, the bearing will continue to work. If there are more of them, please consider ordering new bearings.
- ◆ Fully tighten the screws on each bearing clip.
- ⚠ After the final tightening, the **movement of the smooth rods must be gentle**. If the smooth rod moves stiffly, loosen the screws and repeat the procedure.

STEP 23 Mounting the Y-rod-holder parts

- ◆ Push one of the Y-rod-holders onto the rod. Align the front surface of the plastic part with the flat surface of the rod.
- ◆ Check the correct position of the Y-rod-holders. The screw hole must be facing up and towards the center of the Y-carriage (see the picture).
- ◆ Repeat for the remaining Y-rod-holders.

STEP 24 Installing the Y-carriage

- ◆ Take the Y-carriage including smooth rods with rod holders and place them in YZ-frame. Make sure, that **two bearings are on the left side** (see the picture, there are two pairs of the screw holes on the left and one pair on the right).
- ◆ Secure each Y-rod-holders and fix them with M3x10 screws on the front plate (the one with the longer extrusions). Tighten both screws equally, but not completely. We will tighten them fully later on.
- ◆ Insert the M3x10 screw into the hole in each front holder and tighten them.
- ◆ Secure the second pair of the Y-rod-holder with two M3x10 screws. Tighten both screws equally, but not completely. We will tighten them fully later on.
- ◆ Insert the M3x10 screw into the hole in each rear holder and tighten it.
- ⓘ In case the M3nS nuts keep falling out, please flip the frame upside down. Tighten both printed parts and then return the frame to the original position.

STEP 25 Aligning the smooth rods

! **IMPORTANT:** proper alignment of the smooth rods is crucial to reduce noise and overall friction.

- Move the Y-carriage back and forth across the entire length of the smooth rods to align them.
- Then move the carriage to the front plate and tighten all screws in the front-Y-holders.
- Move the Y-carriage to the rear plate and tighten all screws in the back-Y-holders.

STEP 26 Assembling the Y belt: parts preparation

◆ For the following steps, please prepare:

! **The printed parts are not the same, take a closer look and compare both parts with each other.**

- Y-belt-tensioner (1x) with an oval hole
- Y-belt-holder (1x) with a hexagonal hole
- M3x40 screw (1x)
- M3x10 screw (4x)
- M3nN nut (1x)
- GT2-20 pulley (1x)
- Pin H8 3x20 (1x)
- Y belt (1x)

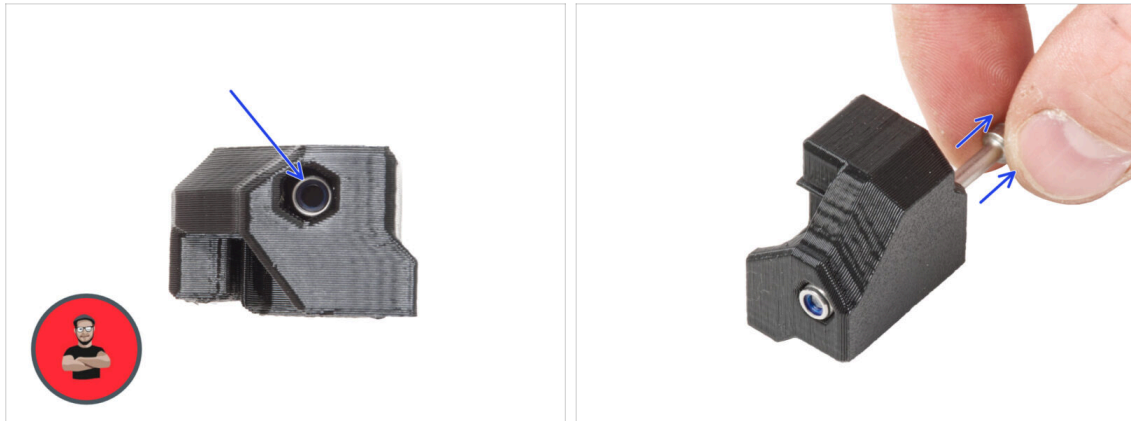
STEP 27 Assembling the Y belt

- ◆ Insert the M3nN nut into the Y-belt-holder.
 - ⓘ Use the screw pulling technique. Attach the M3nN nut on the tip of the M3x40 screw (a few turns are enough). **Do not tighten the screw**, pull the nut all the way into the Y-belt-holder. Don't forget to remove the M3x40 screw from the part and keep it aside for later use.

STEP 28 Assembling the Y belt

- ◆ Lean the printer onto the right side (the one with the PSU) to gain access to the bottom.
- ◆ Push the pin into the pulley and center it.
- ◆ Take one of the Y belt ends and push it into the Y-belt-holder. Note the orientation of the belt (teeth).
- ◆ Secure it by inserting and tightening the M3x10 screw.

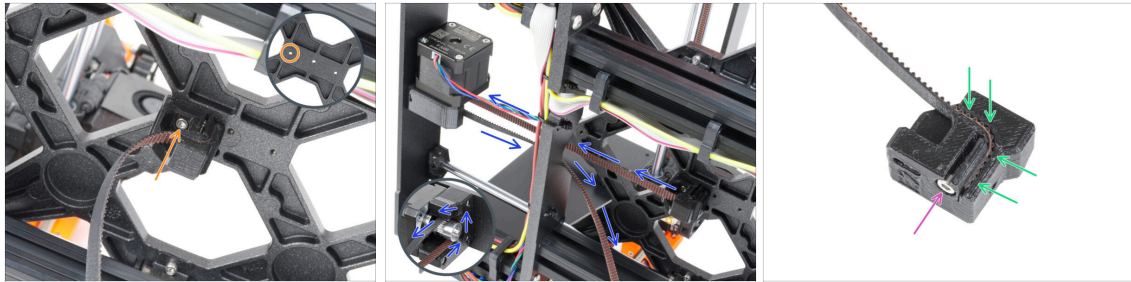
STEP 29 Assembling the Y belt holder

- ◆ Using the M3x10 screw, fix the Y-belt-holder to the Y-carriage. Use the left hole in the center part.
- ◆ Guide the Y-axis belt around the Y-axis motor pulley. Make sure the belt is inside the frame, not under!
- ◆ Take the free end of the Y belt guiding from the pulley and push it into the groove in the Y-belt-tensioner.
- ◆ Secure it with the M3x10 screw.

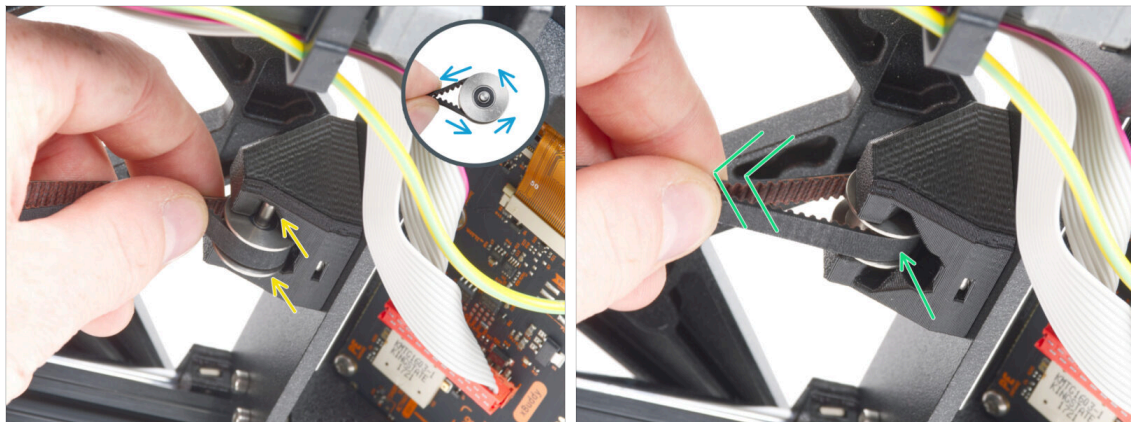
STEP 30 Assembling the Y belt tensioner

- ◆ Take the free end of the belt and guide it around the GT2-20 pulley.
- ◆ Insert the belt with the pulley into the Y-belt-idler on the front rear.
- ◆ Push the pulley all the way inside the printed part and lightly pull on the belt to lock the pulley in place.

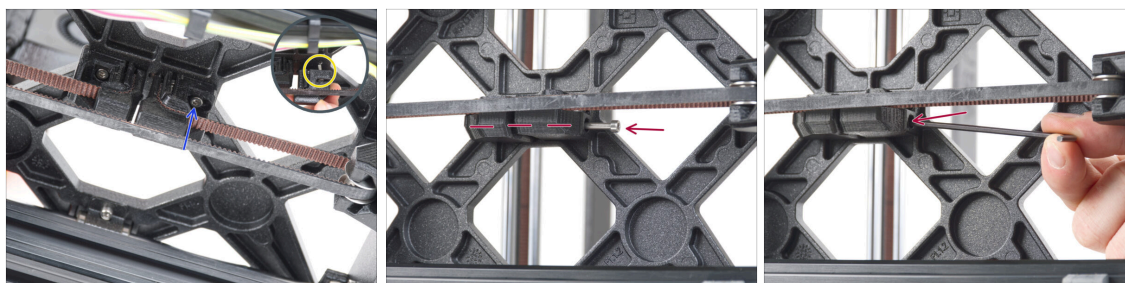
STEP 31 Assembling the Y belt tensioner

- ◆ Insert the M3x10 screw into the Y-belt-tensioner and try if the screw reaches the threaded hole in the Y-carriage when tensioning the belt.
 - ⓘ If the screw does not reach the hole, it is necessary to remove the Y-belt-holder (the one already installed) and reposition the belt by one tooth in both printed parts - one tooth in each printed part will be vacant.
- ◆ Attach the Y-belt-tensioner to the right hole in the Y-carriage and secure it with the M3x10 screw. **Do not overtighten the screw.** We will adjust the exact position later on.
- ◆ Insert the M3x40 screw into the Y-belt-tensioner and tighten it until the screw reaches the nut in the second part.

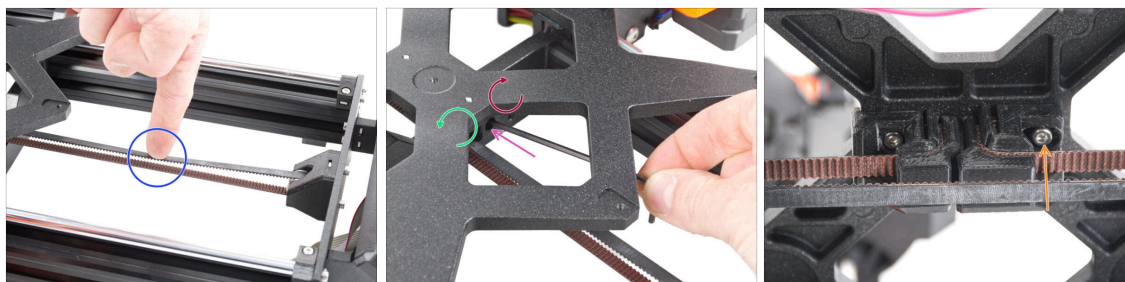
STEP 32 Tensioning the Y belt

- ◆ Move the Y-carriage all the way to the back. Using a finger on your left hand, push the belt down. A medium force should be needed to squish the belt until both the parts touch. Don't try to overstretch the belt as you might damage the printer.
- ◆ You can change the belt tension by adjusting the long M3x40 screw on the bottom of the Y-carriage.
 - ◆ **Tighten the screw** to bring the parts closer together and **increase the tension.**
 - ◆ **Release the screw** to move the parts apart to **decrease the tension.**
- ◆ After you set the correct belt tension, tighten up the M3x10 screw on the bottom to fix the Y-belt-tensioner in place.

STEP 33 Belt tension check

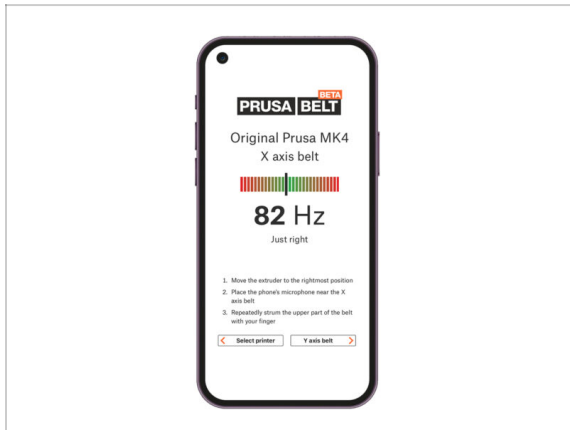

- ⓘ This step is recommended, but optional. If you don't have a phone at your disposal, continue to the next step. You can do this check later on.
- 🛠 To verify or fine-tune the X or Y-axis belt tension on your printer, visit prusa.io/belt-tuner and open up the webpage on your mobile device.
- 🛠 Watch the instructional video on prusa.io/belt-tuner-video and fine-tune your Y belt tension, if required.
- ⓘ The belt tuner app was tested on multiple phones and should work across all most common phone manufacturers. However, in some rare cases it might not work as expected. Please state your brand and model in the comments below the step.

STEP 34 Aligning the Y belt

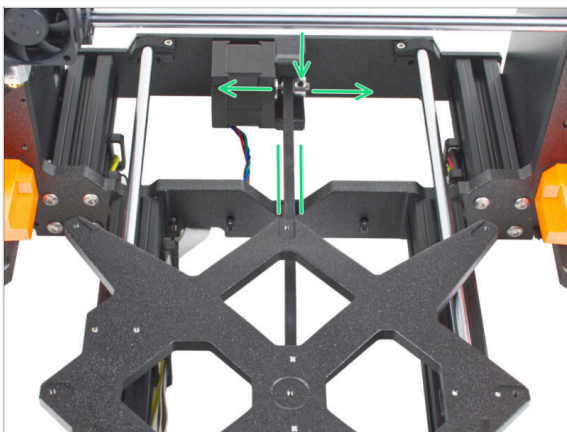

- 🛠 Make sure that both the top and bottom parts of the belt are parallel (directly above each other).
- 🟢 If not, adjust the belt position. Release both screws on the pulley and slightly move with it, until you reach the best position.
- 🛠 Tighten both screws on the pulley.

STEP 35 Installing the Expansion joints: parts preparation

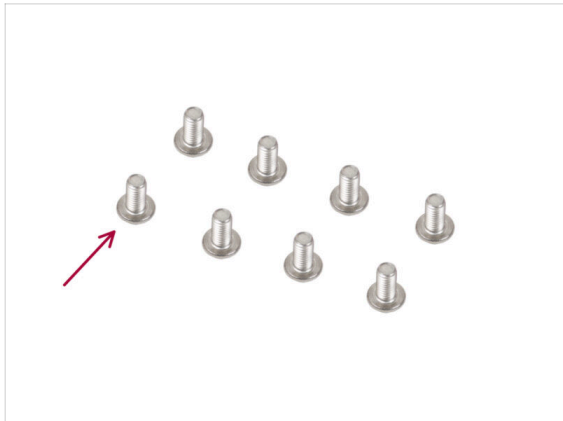

◆ For the following steps, please prepare:

- ◆ Expansion joint (8x)
- ◆ M3x6r screw (8x)

STEP 36 Preparing the expansion joints

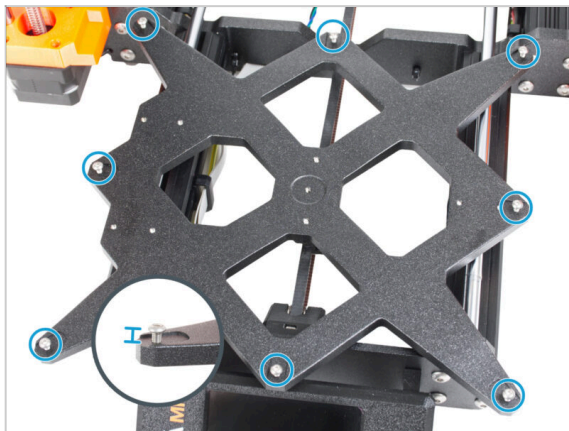

- ◆ Install eight M3x6r screws in the outer holes on the Y-carriage. **Do not tighten them completely.** A few turns are enough for now.

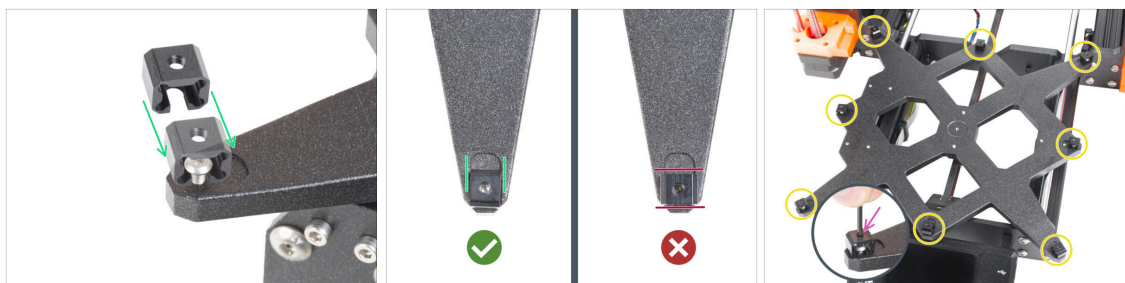
STEP 37 Installing the Expansion joints

⚠ The installation of the expansion joints needs to be done carefully. It is crucial for the correct functionality of the printer. Carefully read the instructions:

- ◆ Slide the expansion joint from the side on the M3x6r screw.
- ⚠** **Make sure the expansion joints are correctly oriented.** There is a recess with approximately the same shape as the expansion joint. The joint must fit into the recess. **See the second picture.**
- ◆ Maintain the position and tighten the M3x6r screw using the 2.0mm Allen key.
- ◆ Proceed the same for the rest of the expansion joints.

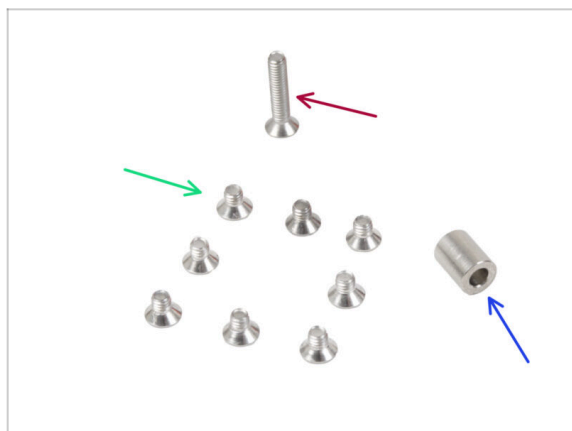
STEP 38 Attaching the heatbed: parts preparation

◆ For the following steps, please prepare:

- ◆ M3x4bT screw (8x)
- ◆ M3x14bT screw (1x)
- ◆ Spacer 3.1x6x8 mm (1x)

STEP 39 Attaching the heatbed

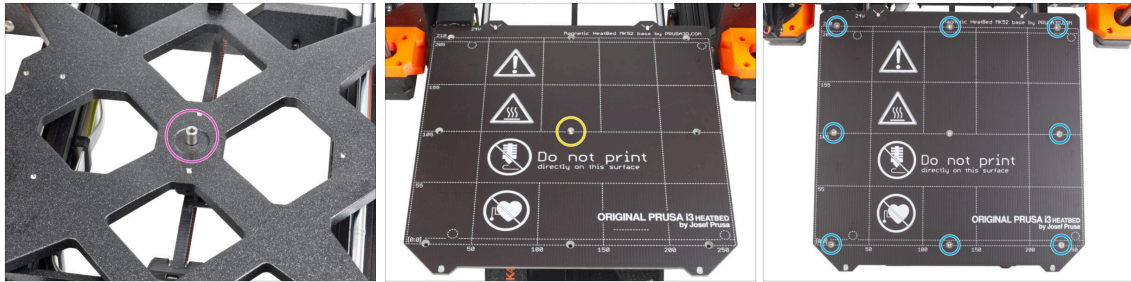

- ◆ Place the spacer onto the Y-carriage and align it with the hole in the center.
- ◆ Put the heatbed on the Y-carriage and secure it by the M3x14bT. **Do not fully tighten the screw yet.**
- ◆ Insert the M3x4bT screws into the remaining holes in the heatbed. **Do not fully tighten the screws yet.**

STEP 40 Tightening the heatbed

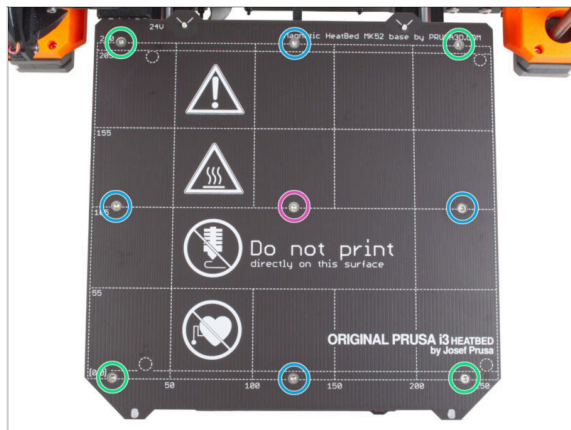

- ◆ After all screws are in place, tighten them in the following sequence:
 - ◆ Center screw
 - ◆ First four screws (edges)
 - ◆ Last four screws (corners)
- ⚠ **Tighten the screws gently, but firmly.**

STEP 41 Guiding the heatbed cables: parts preparation

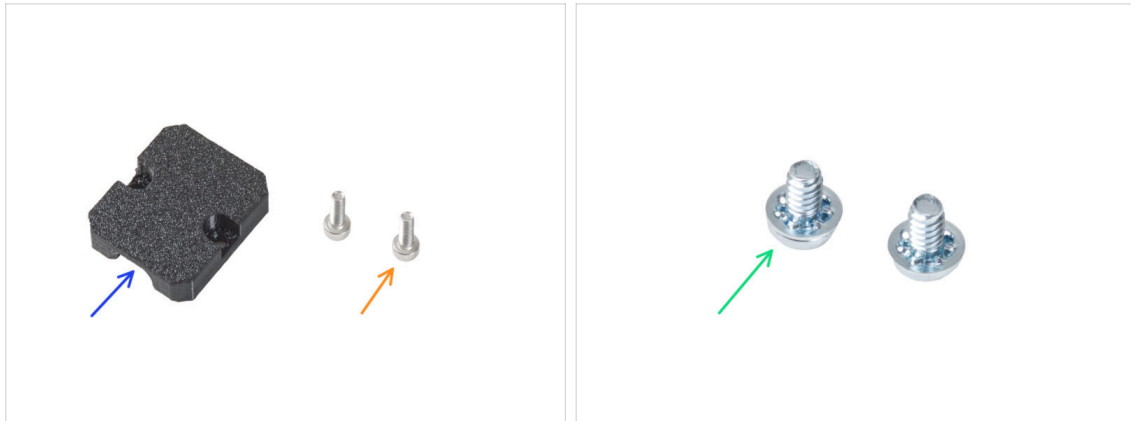

● For the following steps, please prepare:

- Heatbed-cable-holder (1x)
- M3x6 screw (2x)
- Power terminal screw 6/32" (2x)

STEP 42 Guiding the heatbed cables

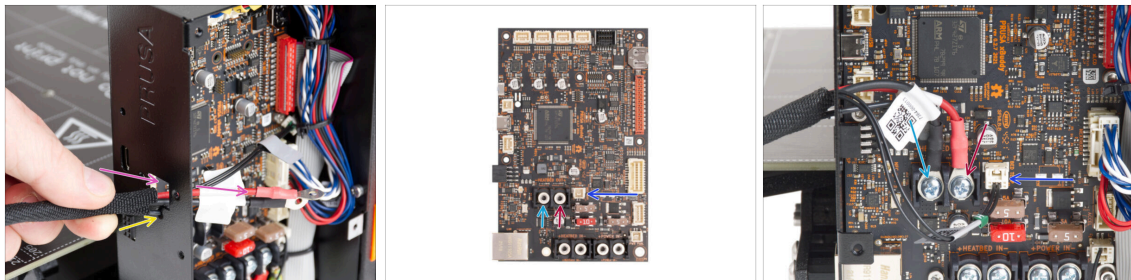

- Push the heatbed cables and heatbed thermistor cable through the square opening on the back of the xBuddy Box.
- Push the filament through the circle hole right below the square opening.
- Place the **black** heatbed cable on the **left** terminal and secure it with the terminal screw.
- Place the **red** heatbed cable on the **right** terminal and secure it with the terminal screw.
- Connect the heatbed thermistor cable to the xBuddy board.

STEP 43 Covering the heatbed cables

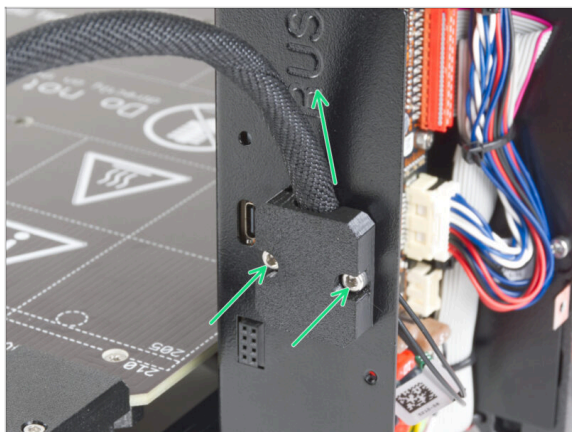

- ◆ Attach the heatbed-cable-holder to the xBuddy box. The cable bundle must be pointing up. Secure it by tightening both M3x6 screws firmly.

STEP 44 Verify all connections once more!

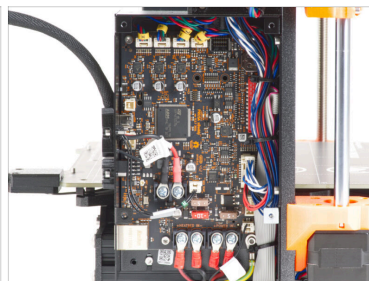
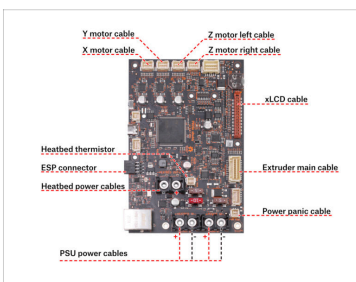
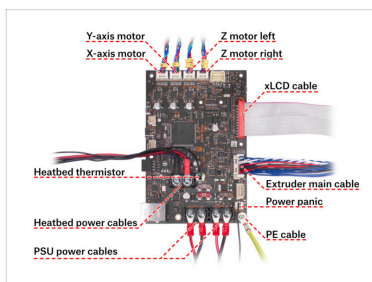

- ◆ Check your electronics connection with the first picture.
- ⚠ Before covering the electronics, check and compare your wiring.
- ◆ Compare your cable management with the third picture.
- ⚠ Make sure that all connectors are fully inserted and PSU cables properly tightened. **Otherwise, there is a risk of damage to the printer!**

STEP 45 Installing the ESP module: parts preparation

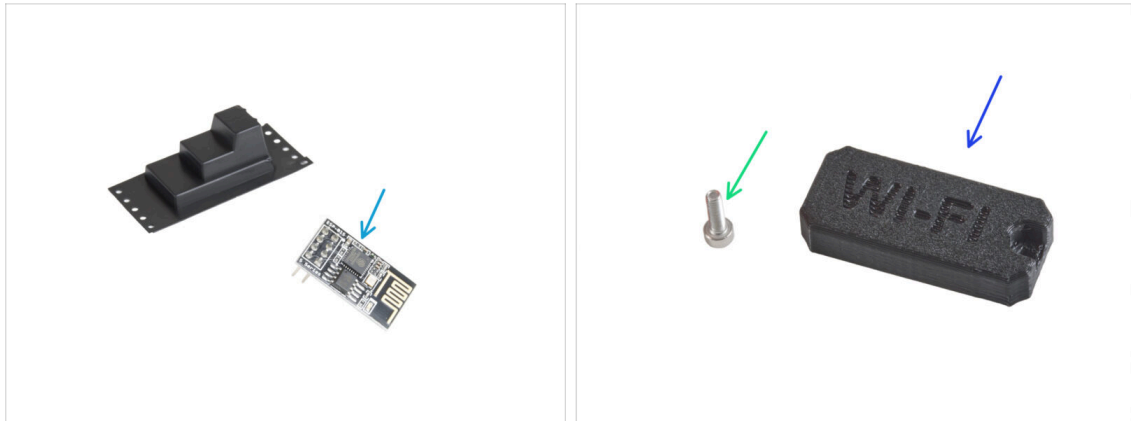

● For the following steps, please prepare:

- ESP-01S Wi-Fi module (1x) *packed in black plastic packaging*
- M3x6 screw (1x)
- Wifi-cover (1x)

STEP 46 Installing the ESP module

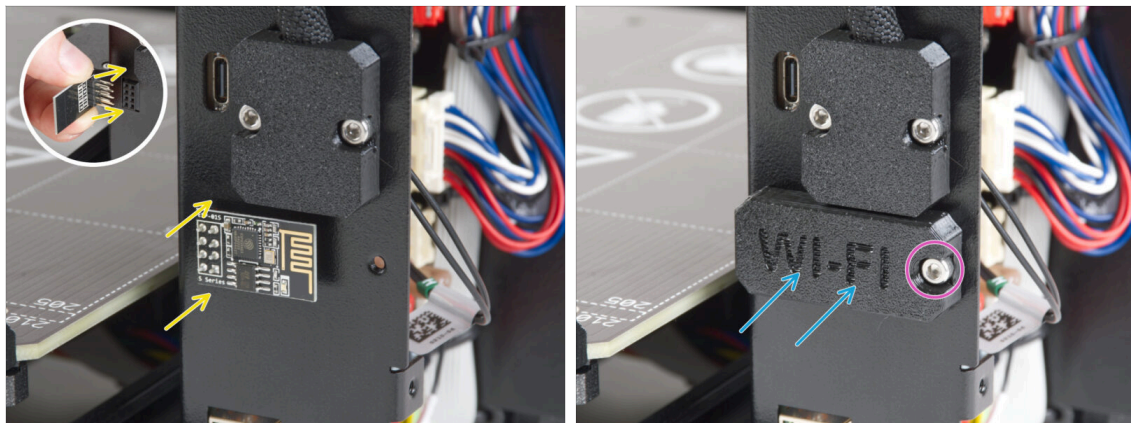

⚠ **Be very careful** when handling and connecting the ESP module to **avoid bending and damaging the pins.**

- **Grasp the ESP Wi-Fi module by the edges of the board** and plug its pins in the eight-hole slot in the xBuddyBox. Make sure the part is correctly oriented. See the second picture.
- Cover the ESP module with the wifi-cover.
- Secure it with the M3x6 screw.

STEP 47 Covering the xBuddyBox: parts preparation



◆ For the following steps, please prepare:

- ◆ xBuddyBox-cover (1x)
- ◆ M3x6 screw (4x)
- ◆ EI-box-cover (1x)
- ◆ M3x10 screw (2x)

STEP 48 Covering the xBuddy Box

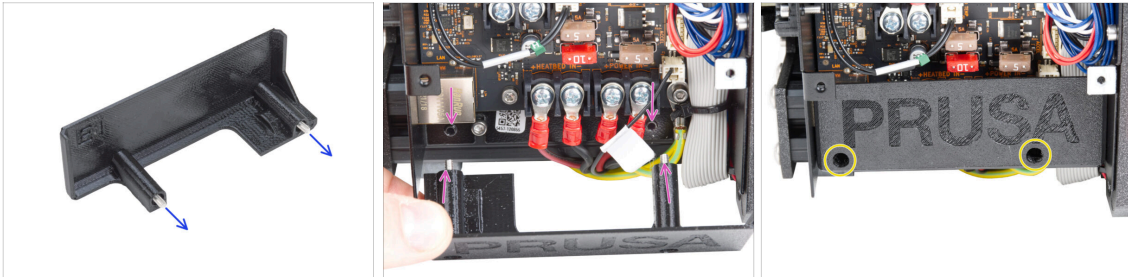

- ◆ Push two M3x10 screws through the ei-box-cover.
- ◆ Insert two M3x10 screws into the ei-box-cover and attach it to the xBuddy Box. There are two threaded holes in the xBuddy Box. Make sure there is no cable in the way for the screws and the cover.
- ◆ Secure the ei-box-cover by tightening both M3x10 screws to the xBuddy Box.

STEP 49 Covering the xBuddyBox

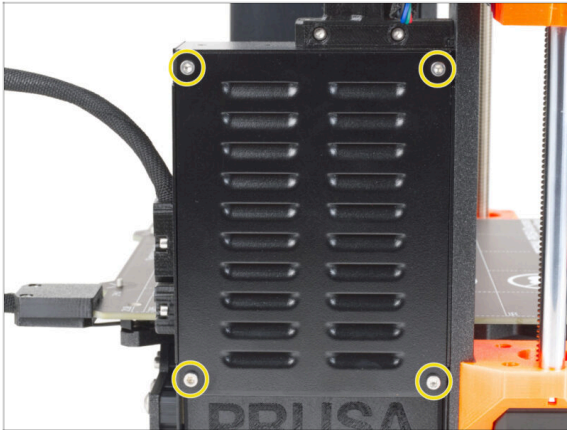

- Align the xBuddy Box cover with the xBuddy Box and secure it with four M3x6 screws.

STEP 50 Assembling the double spool holder (part 1)

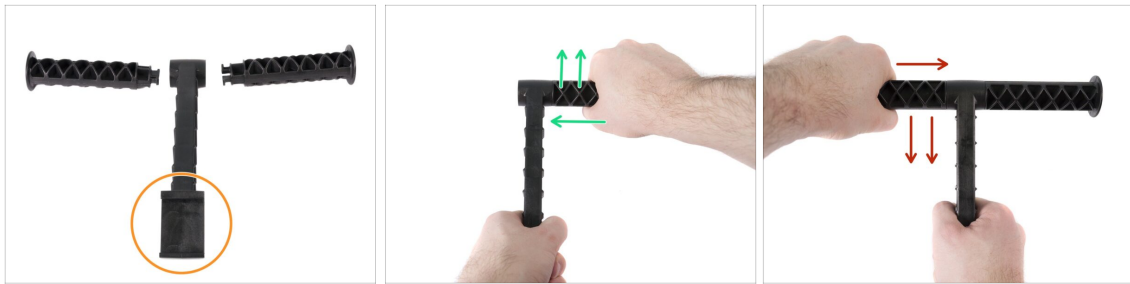

- For the following steps, please prepare:
 - Centre part (1x)
 - Side arm (2x)

STEP 51 Assembling the double spool holder (part 2)

⚠ Don't use excessive force during the assembly, or you might damage the spool holder locking system.

- 🟡 Place all three parts in front of you. Note both "arms" are identical. Make sure the C shaped part, which will snap on the printer's frame is facing towards you.
- 🟢 Take the "arm" on the right side, insert it gently in the main part and start to rotate clockwise (away from you). It should take about half the turn to lock the part in place.
- 🟠 Take the "arm" on the left side, insert it gently in the main part and start to rotate anticlockwise (towards you). It should take about half the turn to lock the part in place.
- 📄 **i** The assembly requires a very small force (torque). If you experience issues, check first the locking mechanism for obstacles.

STEP 52 Assembling the Filament guide: parts preparation

⬛ **For the following steps, please prepare:**

- 🟠 Filament-guide (1x)
- 🟡 Filament guide PTFE tube (2x)
- 🟢 M3n nut (3x)
- 🟠 M3x18 screw (1x)
- 🟡 M3x10 screw (2x)

STEP 53 Filament guide assembly (part 1)

- ◆ Insert two M3n nuts into the marked openings.
- ◆ Use the longer M3x18 screw as a handle for inserting the nut.
- ◆ Insert the two PTFE tubes into the marked openings.
- ◆ Fix the tubes in place with two M3x10 screws from the other side.
- ◆ Insert the third M3n nut into the opening on the side.

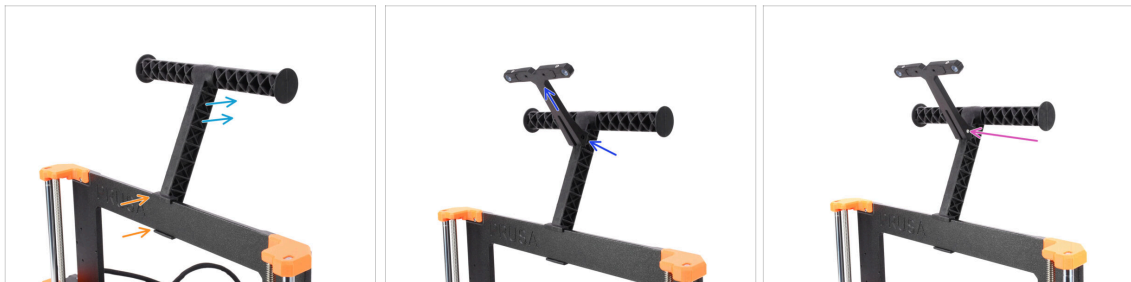
STEP 54 Filament guide assembly (part 2)

- ◆ Attach the spoolholder onto the **middle** of the printer's frame.
- ◆ Make sure the spool holder is inclined towards the back of the printer.
- ◆ Attach the filament guide onto the spool holder.

It should click in inbetween the top two ribs, pointing upwards, as seen in the photo.

- ◆ Fix the guide in place using M3x18 screw.

STEP 55 Haribo time!



- ◆ Eat another five gummy bears.
- ⓘ **Did you know that** the bright colors of gummy bears are achieved through the use of food coloring, which adds to their visual appeal.

STEP 56 That's it



- ◆ That was tough. But you made it!
- ◆ Let's move to the last chapter: **8. Preflight check**

8. Preflight check



STEP 1 Attaching the steel sheet

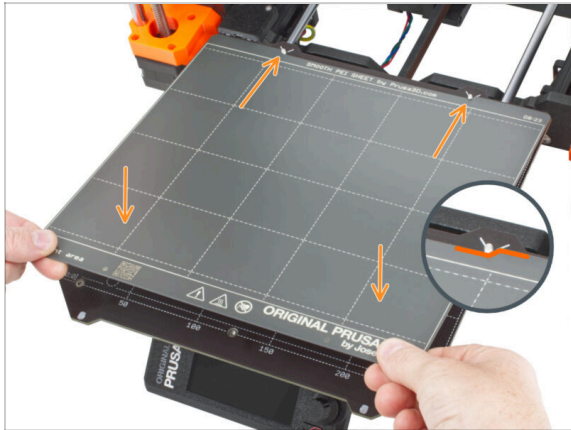

- ⚠** **Make sure there is nothing on the heatbed.** The heatbed must be clean. Any dirt can damage the surface of both the heatbed and the steel sheet.
- 🛠** **Attach the sheet by first aligning the rear cutout with the locking pins on the back of the heated bed** (marked in orange in the picture above). Hold the sheet by the front two corners and slowly lay it down onto the heated bed - **watch your fingers!**
 - 🛠 Keep the **steel sheet** clean for optimum performance.
 - 🛠 #1 cause of prints detaching from the print surface is a greasy steel sheet. **Use IPA (Isopropyl alcohol) to degrease it** if you have touched its surface before.
- ⓘ** We are using a steel sheet with a smooth surface. However, the same procedure applies to other variants.

STEP 2 Firmware update (part 1)

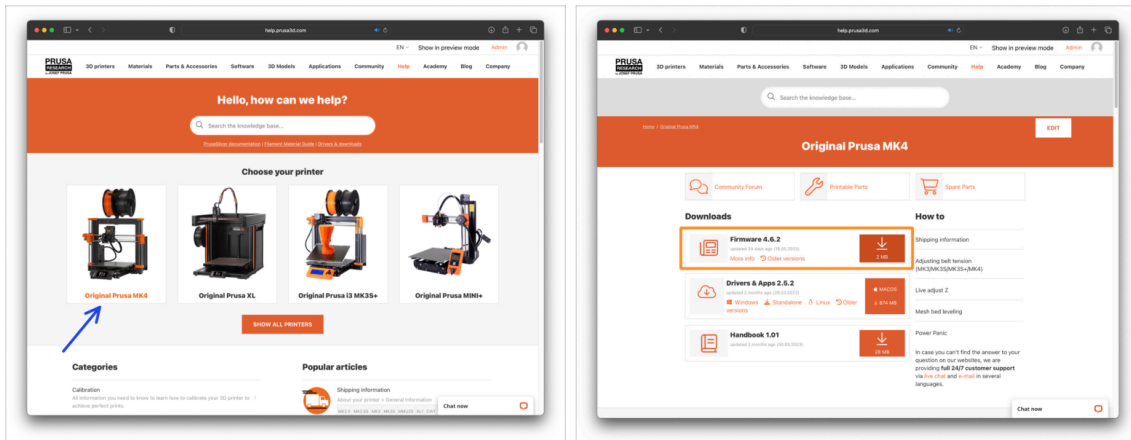

- i All shipped kit units have the latest firmware version. However, it is recommended to check and possibly upgrade the firmware version.
- Visit the help.prusa3d.com page.
- Navigate to the [Original Prusa MK4](#) page.
- Save the firmware file (*.bbf*) onto the bundled USB drive.

STEP 3 Firmware update (part 2)



- Insert the USB drive with the latest firmware file into the printer.
- Connect the power cable and connect the printer into a wall outlet.
- Turn the printer on using the switch on the back.
- If the "New firmware available" screen appears, hit **FLASH** by pressing the rotary knob to upgrade to the latest firmware.
 - If no such message appears, the printer is running the latest firmware already. Proceed to the next step.

STEP 4 Wizard - Selftest start



- ◆ After the printer starts up, the setup wizard will show up - requiring a self-test. Select **CONTINUE** to start.
- i The wizard will test all important components of the printer. The whole process takes a few minutes. Some parts of the wizard require direct user interaction. Follow the instruction on the screen.
- ⚠ **NOTE:** While testing the axes, make sure that there is nothing in the printer obstructing the axes movement.
- ⚠ **WARNING:** Do not touch the printer during the self-test unless prompted! Some parts of the printer may be **HOT** and moving at high speed.
- ◆ The wizard starts with the fan check, Z-axis alignment and the X&Y axis test; all fully automatic.

STEP 5 Wizard - Loadcell Test



- ◆ The next step of the wizard will prompt you to touch the nozzle to test and calibrate the Loadcell. During this procedure, the parts of the printer are not heated up so that you can touch them. Click **Continue**.
- ◆ Do not touch the nozzle yet, wait until prompted by the **Tap nozzle NOW** message.
- ◆ Slightly tap the nozzle from below. No need to use an excessive force. In case the Loadcell does not detect the touch, you will be prompted to repeat the step. Otherwise, you will see **Loadcell test passed OK** when it succeeds.

STEP 6 Wizard - Gearbox Alignment

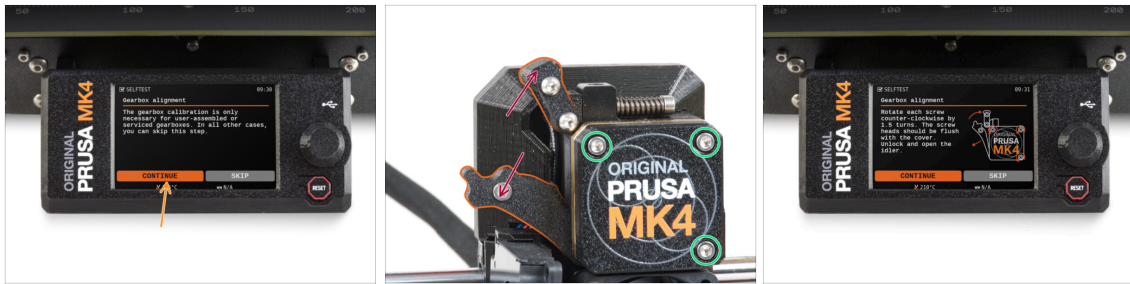

- ◆ Once you get to the Gearbox Alignment part, select **Continue** and follow the on-screen instructions.
- ◆ Undo the idler lock (swivel), then open the idler door.
- ◆ Loosen the three screws on the front of the gearbox by 1.5 turns.
- i The printer will go through the automatic gearbox alignment. This process can't be seen from the outside.
- ◆ Once prompted, tighten the three screws in the pattern indicated on the screen.

STEP 7 Wizard - Filament Sensor Calibration

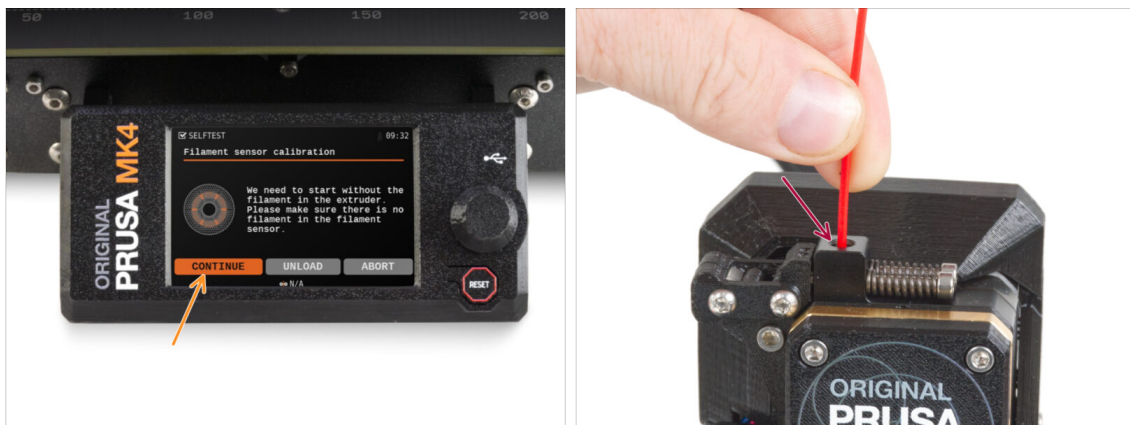

- ◆ During the filament sensor calibration, you will need to use a short piece of filament. Prepare the filament and select **Continue**. There should be no filament inside the extruder before the start of the calibration process.
- i There should be no filament inside the extruder before the calibration process starts.
- ◆ Once prompted to, insert the filament end into the opening on top of the extruder.
- ◆ Remove the filament after the calibration finishes.

STEP 8 Wizard complete



- ◆ **The printer is now fully calibrated.** Follow this guide to the end to load a filament in and start a test print.
- ◆ Once the Wizard finishes, the details screen will show up. **Click the knob** to continue.

STEP 9 Reward yourself!



- ◆ It looks like you have successfully assembled and connected everything. No doubt ;). **Congratulations!** You deserve a big reward for that. Eat all the remaining gummy bears... and don't forget to share with those who supported you during the assembly.
- ⓘ **Did you know that** Haribo gummy bears are one of the most important parts of the Original Prusa printers assembly instructions.

STEP 10 Loading a filament



- Add a spool or a sample of your favourite filament onto either side of the spool holder.
 - Guide the filament end through the filament guide into the extruder. Using the filament guide prevents filament tangling.
 - Once a filament is detected, the printer will load it automatically. It is important to select the correct type of filament you are using on the screen. We recommend using **PLA** material for the first test print.
 - The printer will purge some of the material through the nozzle. Confirm its color is clear by selecting **YES** on the screen and remove the leftover plastic from below the nozzle.
- ! Proceed carefully, the nozzle is now very **HOT!** Do not touch it with your bare hands!

STEP 11 Printable 3D models

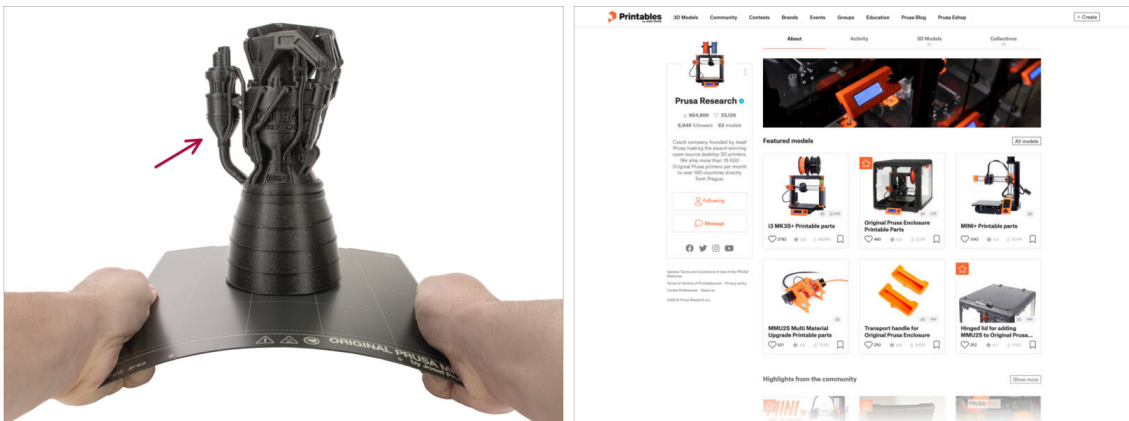

- **The printer is now ready to print!**
- You can start by printing some of our test objects from the bundled USB drive.
- The sample objects are also available on the official [Prusa Research Printables profile](#)

STEP 12 PrusaSlicer for MK4



- 🛡️ Ready to print your own models?
- 📦 Visit help.prusa3d.com once again. Download and install the latest **Drivers & Apps** package onto your computer. This package includes the **PrusaSlicer** app.
- 🟡 Open the **PrusaSlicer** app. If you're running it for the first time, Configuration Wizard will show up. Visit the Prusa FFF tab in the Wizard, select **Original Prusa MK4** in the **0.4mm nozzle** version (the default nozzle size) and hit **Finish** to start using the MK4 printer profile.
- 🟢 Make sure the Original Prusa MK4 is selected in the Printer menu on the right, when slicing for the MK4.
- 🟠 **Import a model** of your choice into PrusaSlicer, adjust the settings if needed, hit **Slice** and export the G-code file onto the USB drive to print it on your MK4..

STEP 13 PrusaLink and Prusa Connect

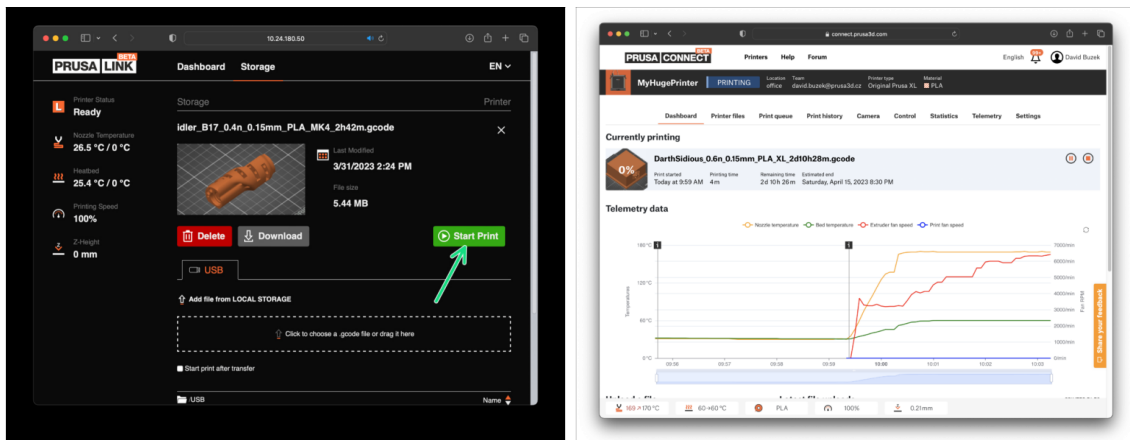

- 🛡️ Did you know you can print and control the printer over the local network with **PrusaLink** or from anywhere in the world using **Prusa Connect**?
- ⚠️ **First, read the article about PrusaLink and Prusa Connect to get general information about these services.**
- 🛡️ To start using these services, follow [this guide](#) to set up the **Wi-Fi** or connect your printer to a network using the wired **Ethernet** connection.

STEP 14 Quick guide for your first prints



 Please read the 3D Printing **Handbook** dedicated to your printer and follow the instructions to set up and use the printer properly. The latest version is always available at help.prusa3d.com

 **Read the Disclaimer and Safety instructions chapters.**

STEP 15 Prusa knowledge base

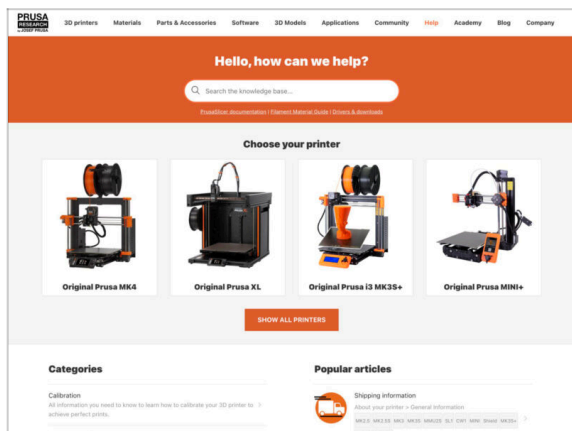

 If you encounter any problems at all, don't forget you can always check out our knowledge base at help.prusa3d.com

 We're adding new topics every day!

STEP 16 Join Printables!

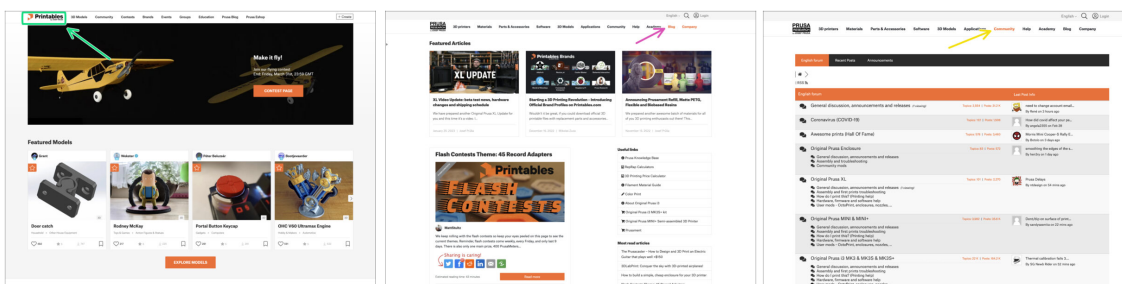

 Don't forget to join the biggest Prusa community! Download the latest models in STL or G-code tailored for your printer. Register at [Printables.com](https://printables.com)

 Looking for inspiration on new projects? Check our blog for weekly updates.

 If you need help with the build, check out our forum with a great community :-)

 All Prusa services share one user account.

Manual changelog MK4 kit

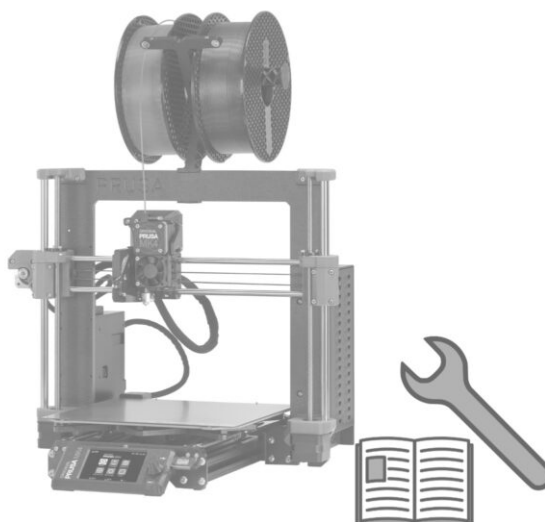

STEP 1 Version history

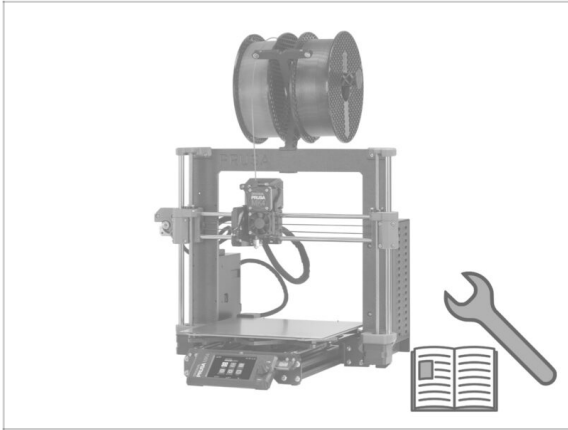

- ◆ **Versions of the MK4 manual:**
- ◆ 06/2023 - Initial version 1.0

